



---

Modification: engines 605 and 606 included

Installation instructions

## **Tempomat/cruise control**

**54.3**

Models 124.1/3 with automatic transmission, left-hand steering (except models 124.128/133/193/333/393)

Tempomat/cruise control permits holding any speed above approx. 40 km/h by actuating the operating switch.

The installation instructions are subdivided into the following sections:

- A. Installation of switch, control module and wiring harness
- B. Installation of actuator on engines 601, 602 and 603
- C. Installation of actuator on engine 605
- D. Installation of actuator on engine 606
- E. Wiring diagrams
- F. Parts ordering note

### **A. Installation of switch, control module and wiring harness**

- 1 Disconnect battery and remove.

**On vehicles with engines 601, 602 or 603,  
perform items 2 through 4.**

- 2 Remove battery.

3 Partially pull off seal (a) on right-hand side, remove clamps (b) and take off cover (c).

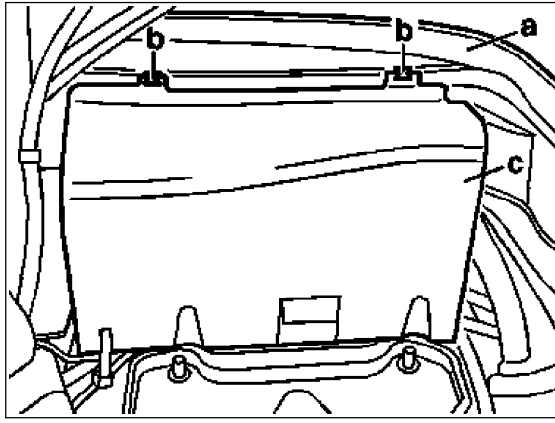

P30.30-0224-13

4 Pull off relay, loosen relay holder (d) and place to side.

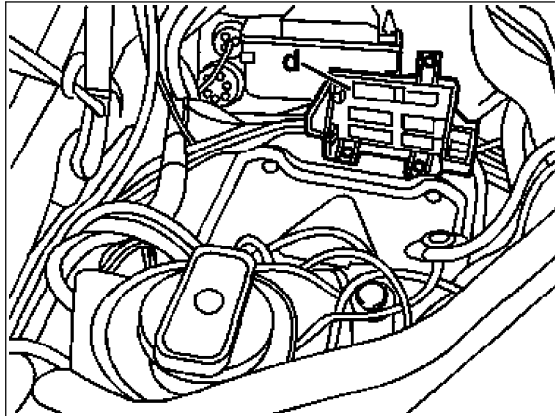

P30.30-0225-13

5 Remove both covers from fuse and relay box. Then loosen fuse carrier (e) and place to side.

6 Remove floor mat at front left.

7 Remove steering wheel (RI 46-4280).

8 Remove both covers on the left side below the instrument panel (RI 68-150).

9 Remove instrument cluster (RI 54-6015).

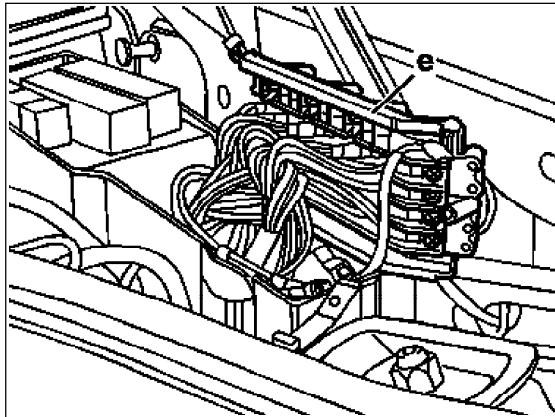

P30.30-0226-13

10 Attach 6-pin connector (arrow) from cruise control wiring harness to strut.

11 Install ground cable and green/yellow cable with 1-pin connector to cutout for instrument cluster.

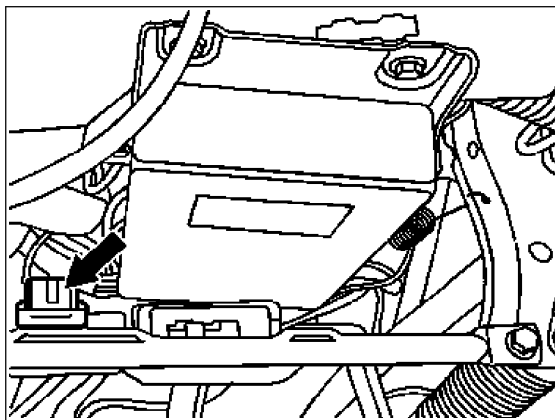

P30.30-0227-13

12 Mount 2-pin intermediate plug of Tempomat/cruise control wiring harness between wiring harness (40) and stop lamp switch (X20).

X20 Stop lamp switch intermediate connector

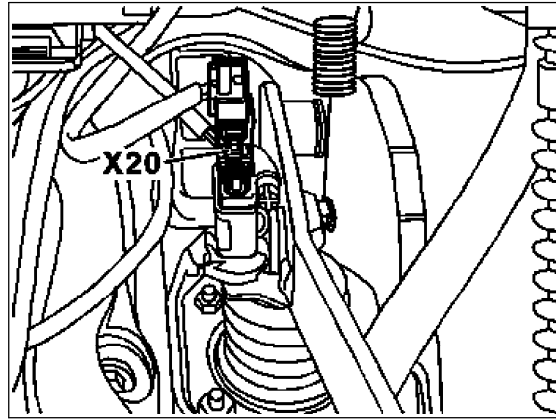

P30.30-0228-13

13 On vehicles where the stop lamp switch is already contacted in-between, disconnect wiring harnesses and install new wiring harness from stop lamp switch to fuse and relay box (F1) instead and fasten laterally with clips. Then connect all wiring harnesses to stop lamp switch multipoint connector (X21).

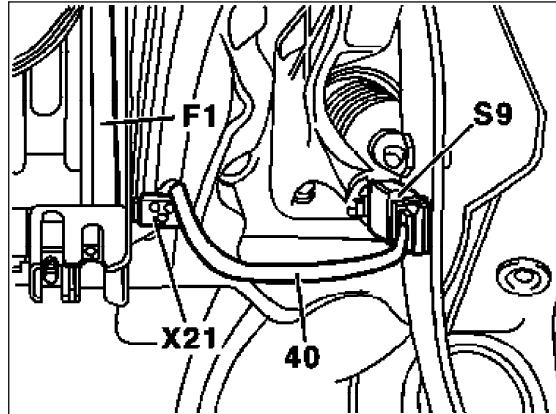

P30.30-0229-13

14 Screw control module (N4/2) to holder (1) and reference resistor (R29) to control module, if necessary. Screw holder with control module to bottom of instrument panel and connect 14-pin connector of Tempomat/cruise control wiring harness to control module.

- 1 Holder
- 2 Screw B 4.8\_ 13
- 3 Screw B 4.8\_ 13
- N4/2 CC control module with reference resistor
- R29 CC control module reference resistor

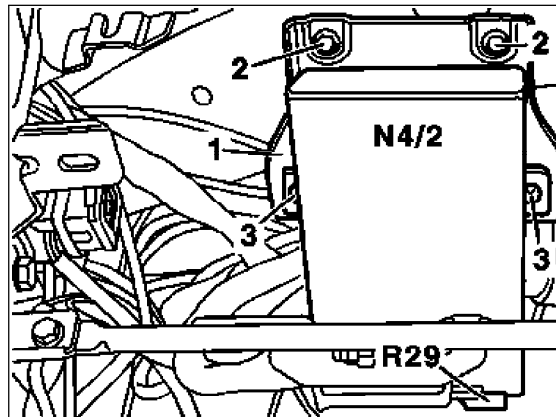

P30.30-0230-13

15 Install 8-pin connector of Tempomat/cruise control wiring harness from inside through fuse and relay box into engine compartment (arrows).

**On vehicles with engines 601, 602 and 603, perform items 16 and 17**

16 Install Tempomat/cruise control wiring harness from left to right under blower housing.

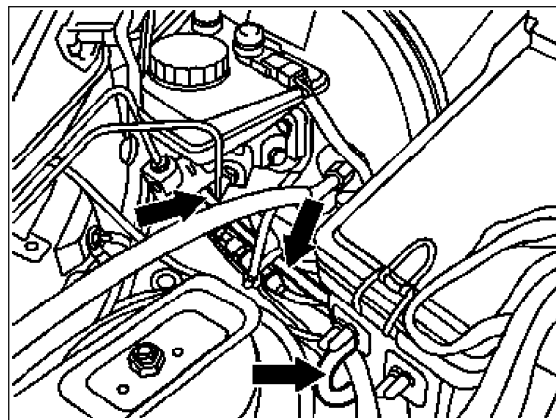

P30.30-0231-13

17 Mount holder between wheelhouse and coolant expansion tank. Attach 8-pin connector of Tempomat/cruise control wiring harness to holder.

Engines 601, 602 and 603

- 5 Holder
- 6 Tempomat/cruise control wiring harness

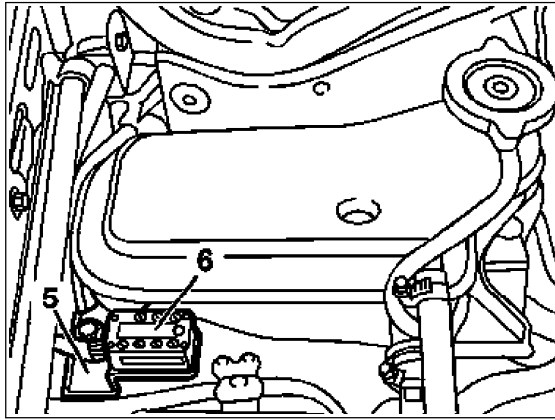

P30.30-0232-13

**On vehicles with engines 605 and 606, perform item 18.**

18 Mount holder (1) for Tempomat/cruise control wiring harness (6), clip in connector and fasten wiring harness with cable straps.

- 1 Holder
- 6 Tempomat/cruise control wiring harness

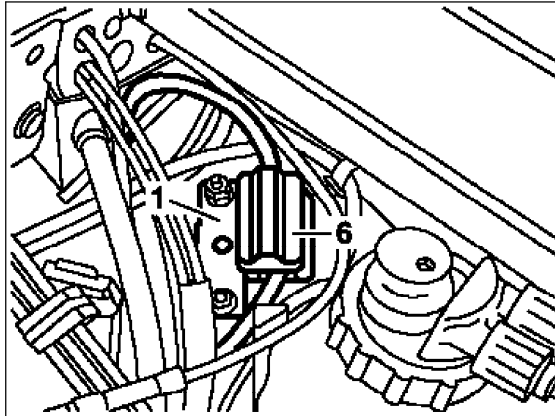

P54-6678-13

**On vehicles without Hall-effect sensor, perform items 18-21**

19 Install wiring harness for Hall-effect sensor from cutout of instrument cluster to grounding point (arrow). Connect ground cable together with ground cable of Tempomat/cruise control wiring harness.

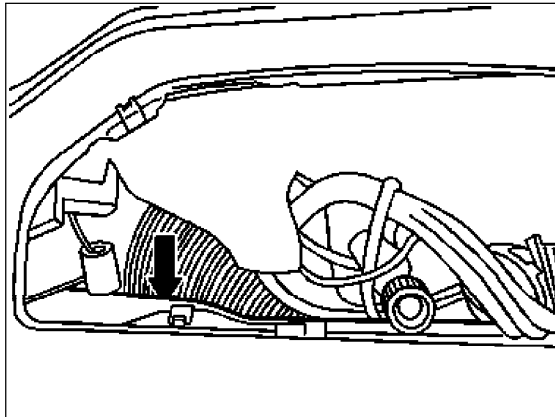

P30.30-0233-13

20 Route black/red/purple wire from wiring harness for hall sensor to fuse carrier (e) and connect to outlet for fuse 5. Reinstall fuse carrier and cover for fuse and relay box.

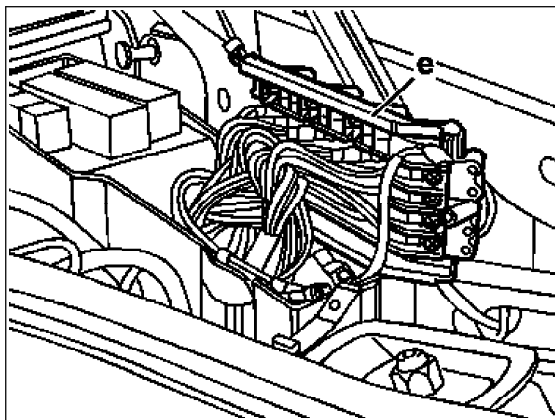

P30.30-0226-13

21 Break out cutout for Hall-effect sensor (arrow) on instrument cluster.

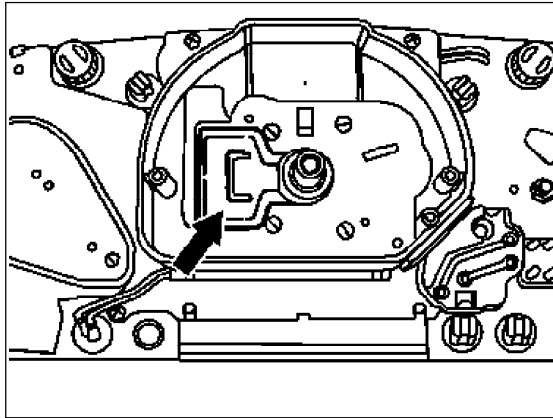

P30.30-0234-13

22 Screw Hall-effect sensor to instrument cluster (arrow).

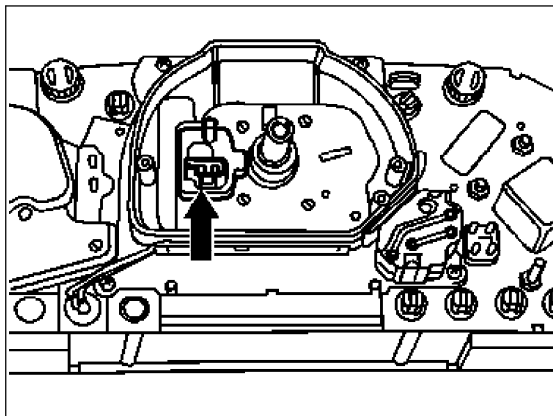

P30.30-0235-13

**Note**

On vehicles with Hall-effect sensor, install Hall-effect sensor multipoint connector with holder. Connect all speed signal cables to Hall-effect sensor multipoint connector.

21 Install instrument cluster, while also installing the auxiliary wiring harnesses for Tempomat/ cruise control and Hall effect sensor or multipoint connector.

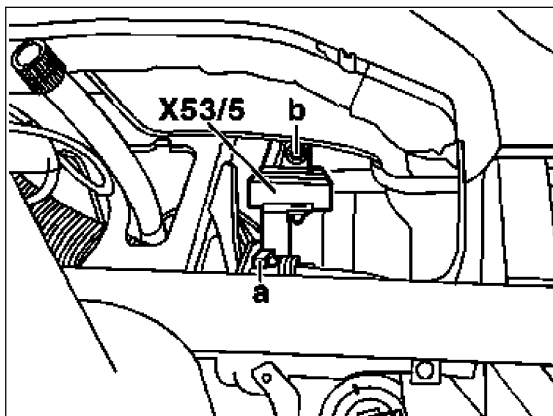

P30.30-0236-13

- X53/5 Hall-effect sensor multipoint connector
- a Nut M10 (steering column console)
- b Nut M6 (heater box)

24 Remove combination switch. (RI 54-2800).

25 Remove lining for jacket tube and install new lining (RI 46-7700).

26 Push CC switch (S40) onto fastening plate of combination switch.

27 Mount both switches.

28 Install jacket tube bracket (1) and fasten.

29 Press combination switch plug onto the connector again.

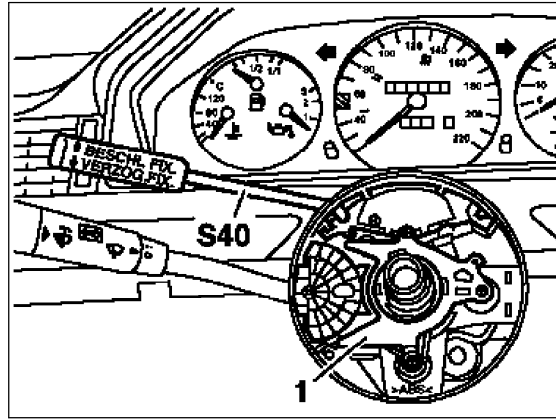

P54-6642-13

30 Install wiring harness of Tempomat/cruise control switch (S40) toward connector of Tempomat/cruise control wiring harness and press on.

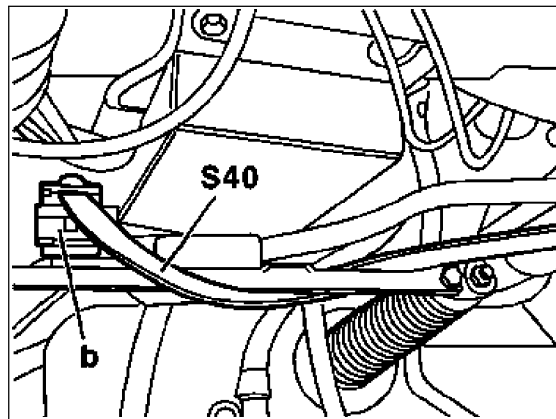

P30.30-0237-13

31 Install covers under instrument panel (RI 68-150).

32 Install steering wheel (RI 46-4280)

33 Put in floor mat.

## B. Installation of actuator on engines 601, 602 and 603

1 Rotate drive shaft of actuator (M16) up to the stop in the opposite direction to the arrow. Screw on lever (2) and lock.

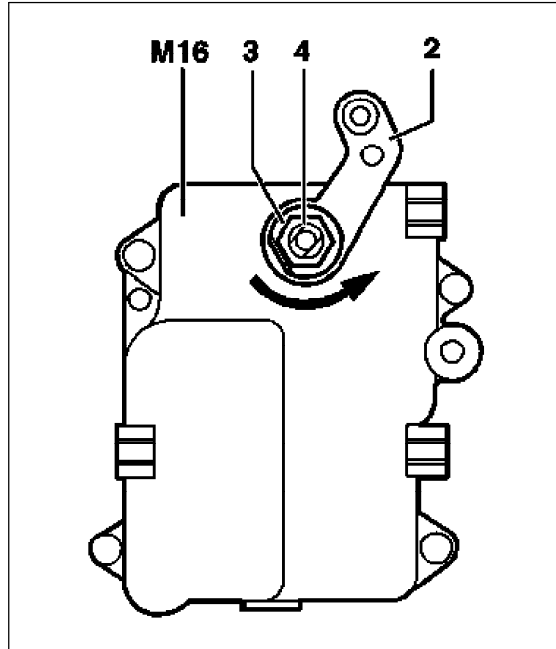

- 2 Lever
- 3 Lock washer
- 4 Nut MB 8\_\_1
- M16 Cruise control actuator

P30.30-0238-15

2 Screw holder on to actuator.

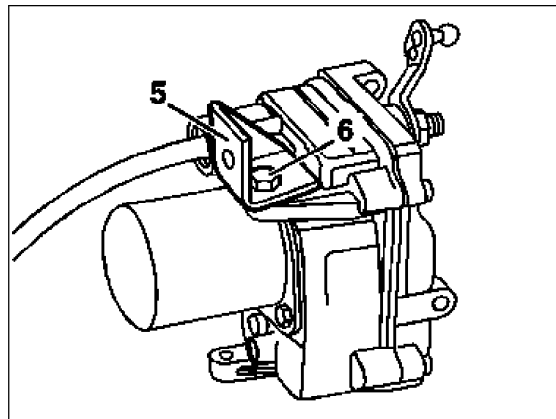

- 5 Holder
- 6 Screw M6\_\_12

P30.30-0239-13

3 Mount rubber grommet on holder and insert spacers as shown.

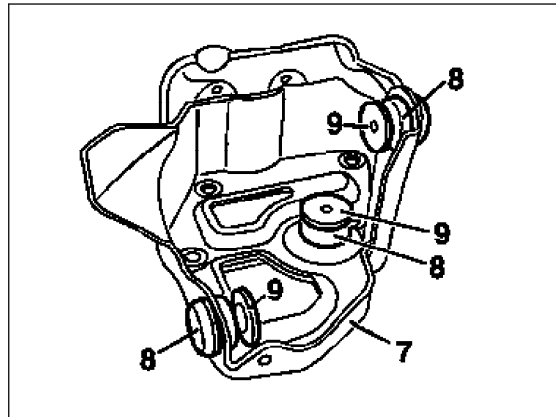

- 7 Holder
- 8 Rubber grommet
- 9 Spacer

P30.30-0240-13

4 Insert actuator in holder and fasten.

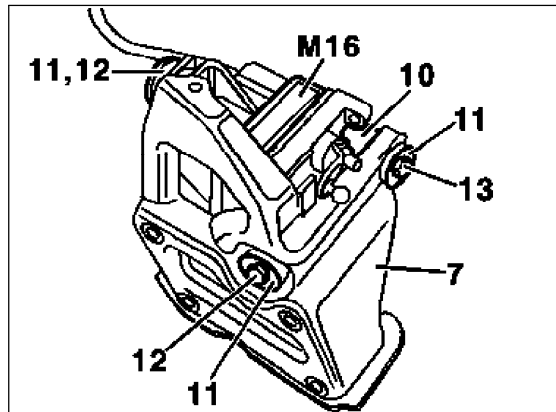

- 7 Holder
- 10 Spacer
- 11 Washer
- 12 Screw M6x28
- 13 Screw M6x45
- M16 Cruise control actuator

P30.30-0241-13

5 Screw holder with actuator to cylinder head.

- 7 Holder
- 14 Screw M6x18
- 15 Washer A6.4
- M16 Cruise control actuator

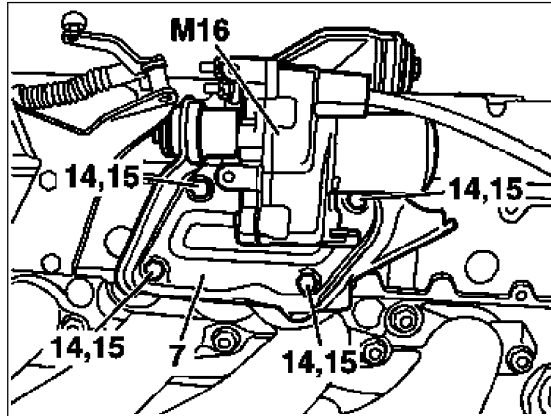

P30.30-0242-13

6 Install wiring harness from actuator (M16) to holder on coolant expansion tank (arrows) and fasten. Then push plug on 8-pin connector (M16).

- 19 Holding clamp

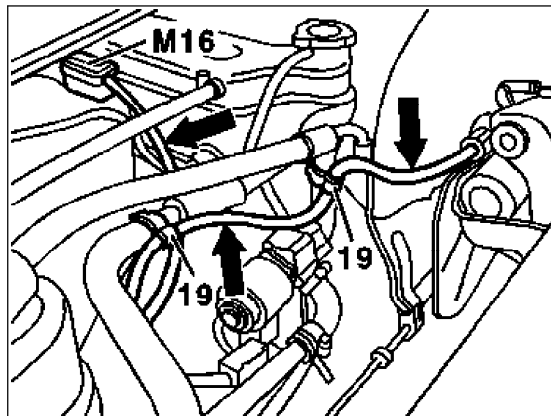

P30.30-0243-13

7 Screw ball head (20) to throttle control lever.

- 20 Ball head
- 22 Nut M5

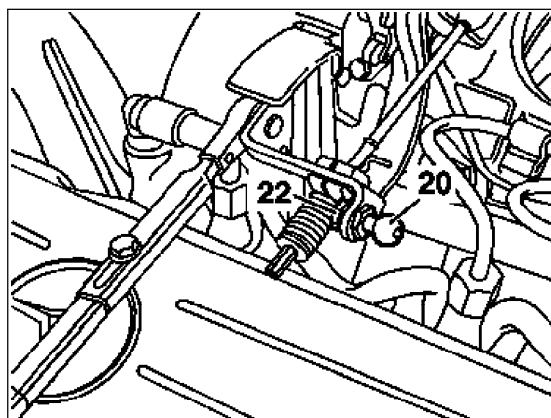

P30.30-0244-13

8 Move throttle control to idle speed position.

9 Push lever of actuator away from engine into idle speed position.

10 Adjust connecting rod so that it is approx. 1 mm shorter than the actual distance.



11 Attach connecting rod (21).

12 Connect battery.

13 Perform function test.

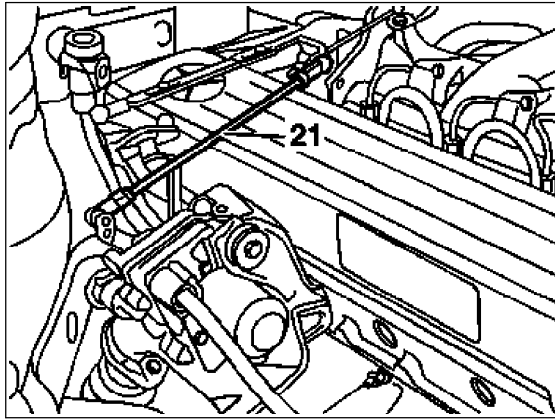

P30.30-0245-13

### C. Installation of actuator on engine 605

1 Remove air cleaner cross pipe (RI 09-8031).

2 Remove transfer lever of throttle control.

3 Remove intake manifold (RI 14-1310).

- a Air cleaner cross pipe
- b Transfer lever
- c Cylinder head cover trim
- d Intake manifold

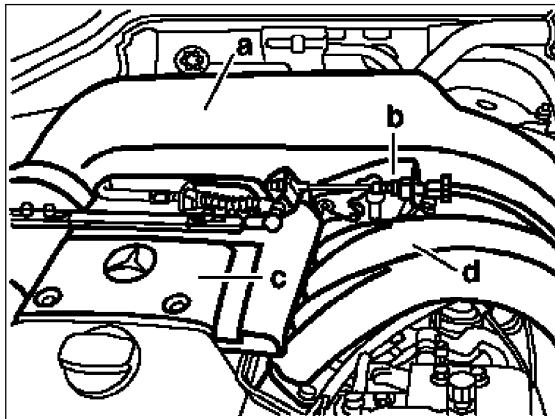

P54-6644-13

4 Rotate drive shaft of actuator (M16) up to the stop in the opposite direction to the arrow. Screw on lever (4) and lock.

- 4 Lever
- 5 Lock washer
- 6 Nut M8x1
- M16 Cruise control actuator

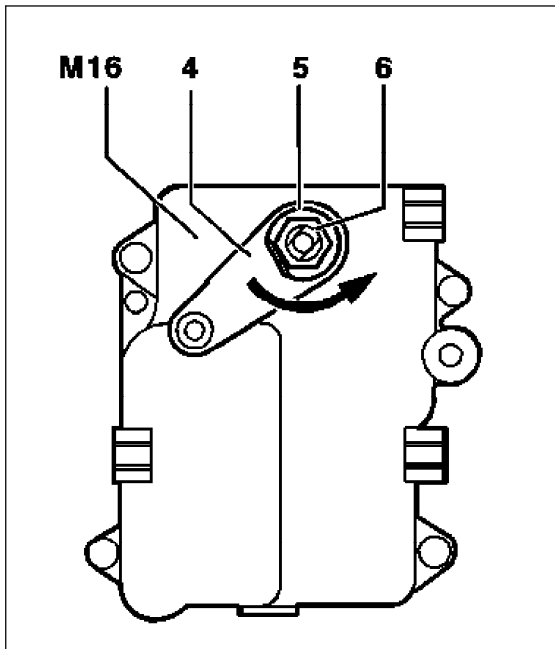

P30.30-0246-15

5 Install new engine mount on the left.

6 Mount holder (1) on engine mount.

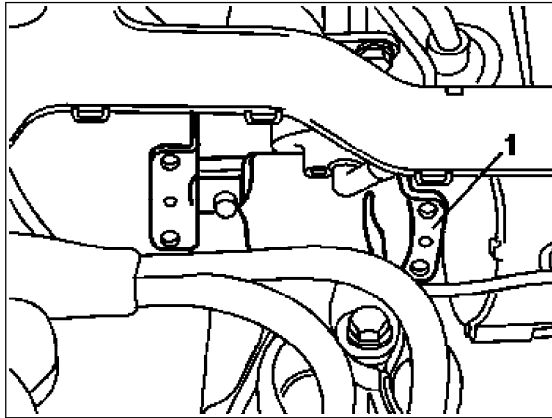

P30.30-0247-13

7 Install actuator (M16) on holder (7) and fasten.

- 7 Holder
- 10 Spacer
- 11 Washer
- 12 Screw M6x28
- 13 Screw M6x45
- M16 Cruise control actuator

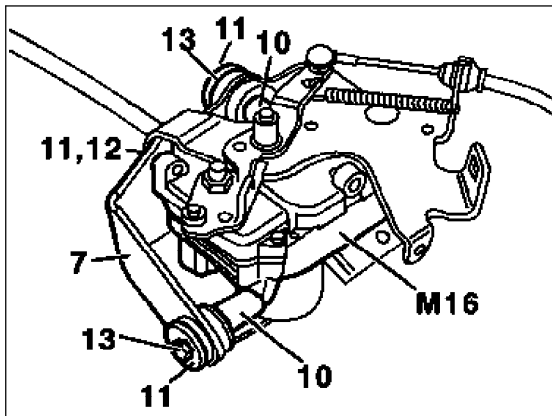

P30.30-0248-13

8 Install actuator.



Clearance must be present between the actuator and steering lines on the steering gear.

**On vehicles without clearance perform items 9 and 10.**

9 Remove connection tube for low pressure line.

10 Install new connection line (19).

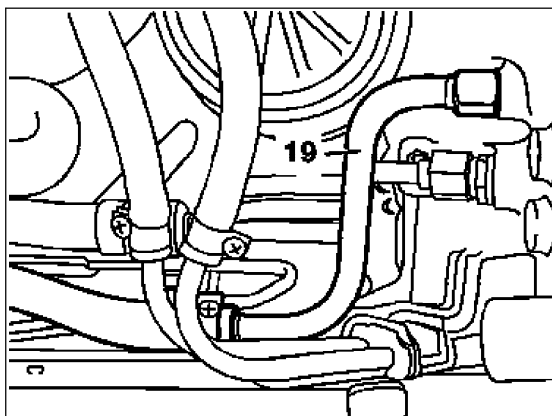

P30.30-0249-13

11 Install cable of actuator (M16) to 8-pin connector of auxiliary harness and fasten. Connect plug to 8-pin connector of auxiliary wiring harness.

12 Replace Bowden cable for accelerator pedal/throttle control with a new one (RI 30-3402).

- 14 Clip
- 15 Cable strap
- 16 Clip
- 17 Clip
- M16 Cruise control actuator

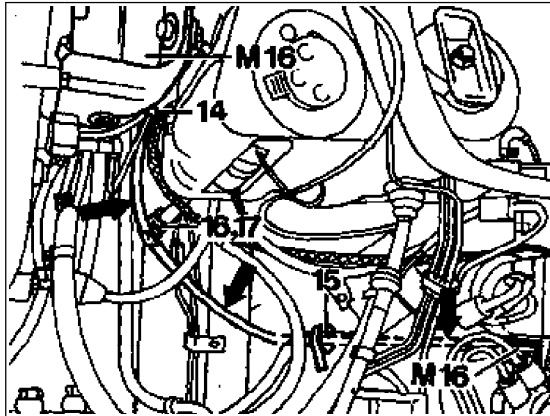

P30.30-0255-13

13 Install intake manifold (RI 14-1310).

14 Install transfer lever of throttle control.

15 Install and adjust Bowden cable of actuator to throttle control lever (RI 30-561).

16 Install air cleaner cross pipe (RI 09-8031).

17 Connect battery.

18 Check oil level of power steering, correct if necessary.

19 Perform function test.

#### D. Installation of actuator on engine 606

1 Remove air cleaner cross pipe (RI 09-8031).

2 Remove transfer lever of throttle control.

3 Remove intake manifold (RI 14-1310).

- a Air cleaner cross pipe
- b Transfer lever
- c Cylinder head cover trim
- d Intake manifold

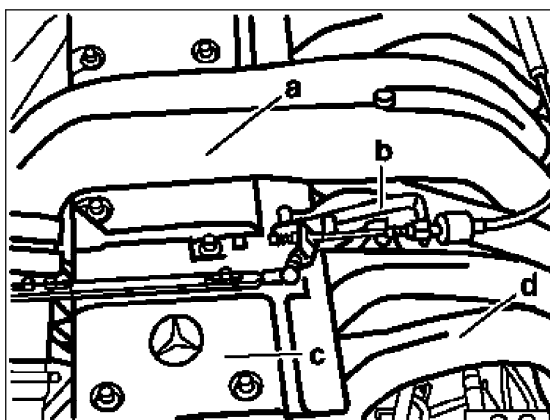

P54-6648-13

4 Rotate drive shaft of actuator (M16) up to the stop in the opposite direction to the arrow. Screw on lever (4) and lock.

- 4 Lever
- 5 Lock washer
- 6 Nut M8x1
- M16 Cruise control actuator

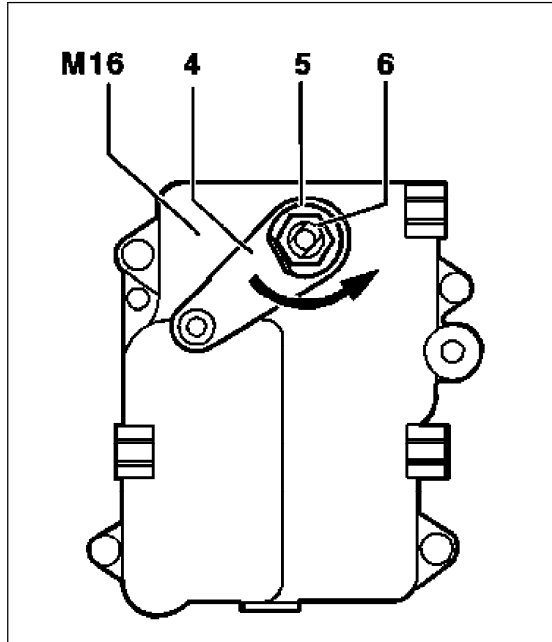

P30.30-0246-15

5 Install actuator (M16) in the two-piece holder (7) and fasten as shown in the illustration.

- 7 Two-piece holder
- M16 Cruise control actuator

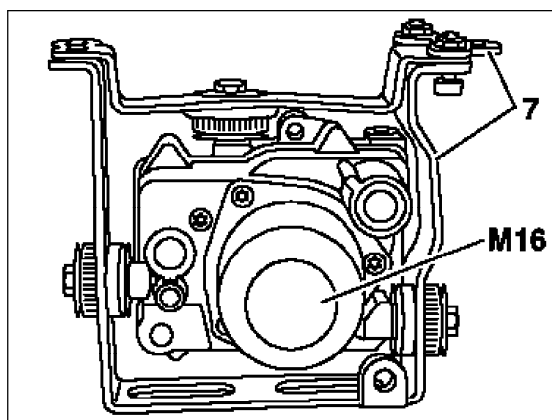

P54-6645-13

6 Unscrew the two screws (arrow) on the rear bracket of the injection pump and screw on bracket (7) with actuator (M16).

**Note**

The anti-jerk control module can be rotated when space is limited.

- 7 Two-piece holder
- M16 Cruise control actuator

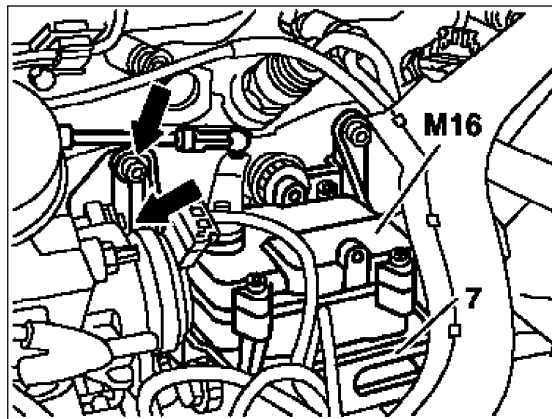

P54-6646-13

7 Route cable of actuator (M16) to 8-pin connector of auxiliary harness and fasten. Press plug onto the 8-pin connector of auxiliary wiring harness.

- 14 Clip
- 15 Cable strap
- 16 Clip
- 17 Clip
- M16 Cruise control actuator

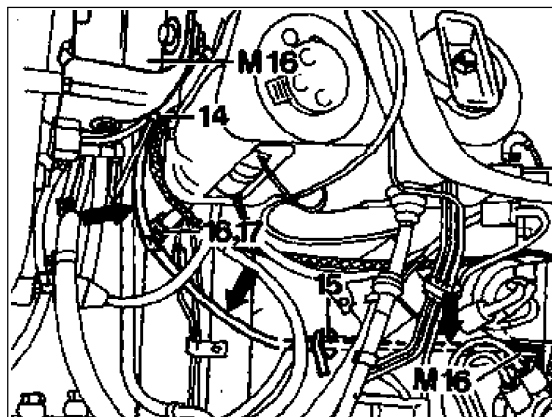

P30.30-0255-13

8 Move throttle control into idle position and attach connecting rod (21) to ball head.

9 Press actuator lever into the idle position.

10 Adjust the connecting rod (21) so that it is approx. 1 mm shorter than the actual distance. Attach connecting rod to actuator (M16).

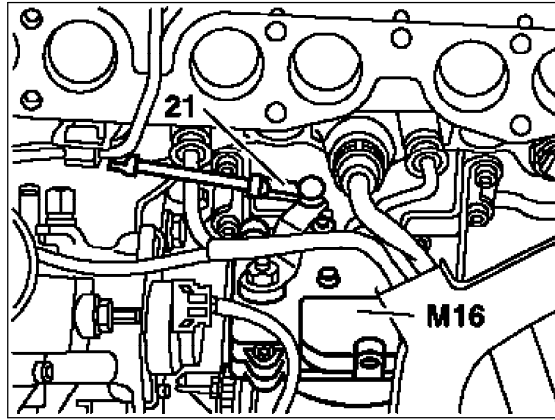

P54-6643-13

11 Install intake manifold (RI 14-1310).

12 Install transfer lever of throttle control.

13 Install air cleaner cross pipe (RI 09-8031).

14 Connect battery.

15 Perform function test.

## E. Wiring diagrams



A new control module with reference resistor is being phased in, it does not affect the wiring or wiring diagrams.

N4/2 CC control module  
R29 CC reference resistor

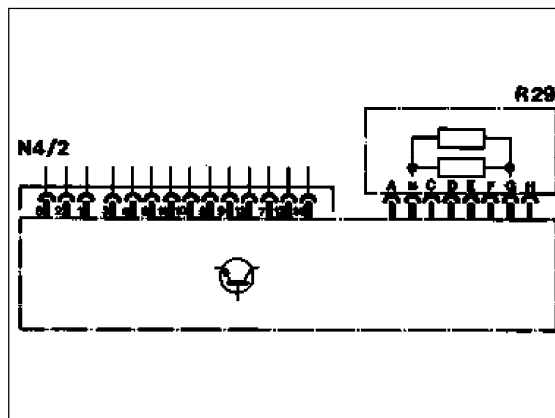

P30.30-0252-13

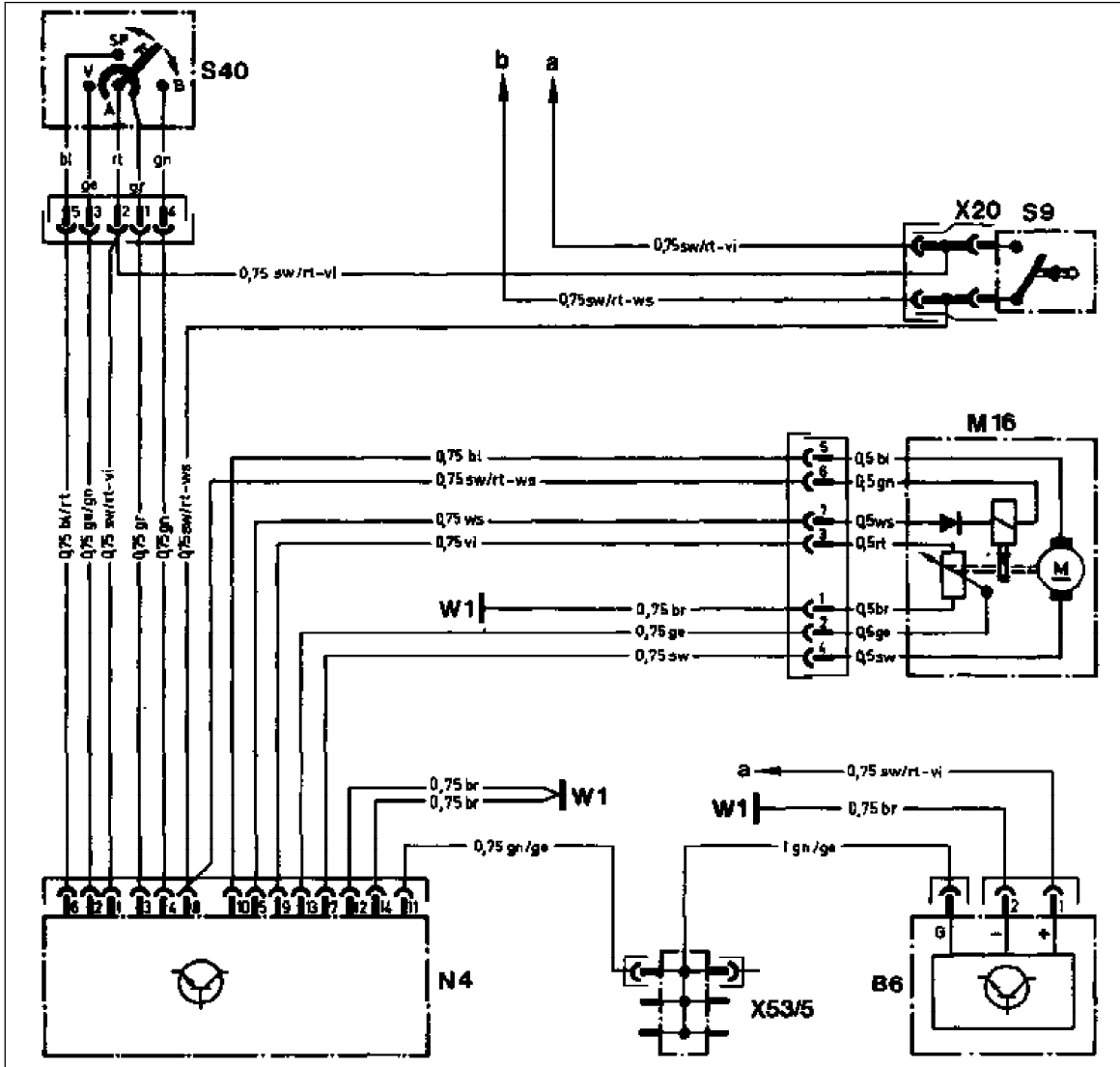

P30.30-0253-59

### Tempomat/cruise control wiring diagram, model 124.120

a	On fuse 5, terminal 15	W1	Main ground (behind instrument cluster)
b	On N7 exterior lamp failure monitoring unit 15	X20	Stop lamp switch intermediate connector (2-pin)
B6	Hall-effect speed sensor	X53/5	Hall-effect sensor multipoint connector, 6-pin (only if speed signal is required for several options)
M16	Cruise control actuator		
N4	CC control module		
S9	Stop lamp switch (2-pin)		
S40	Tempomat/cruise control switch		
	A = Off		
	B = Accelerate		
	SP = Resume		
	V = Decelerate		

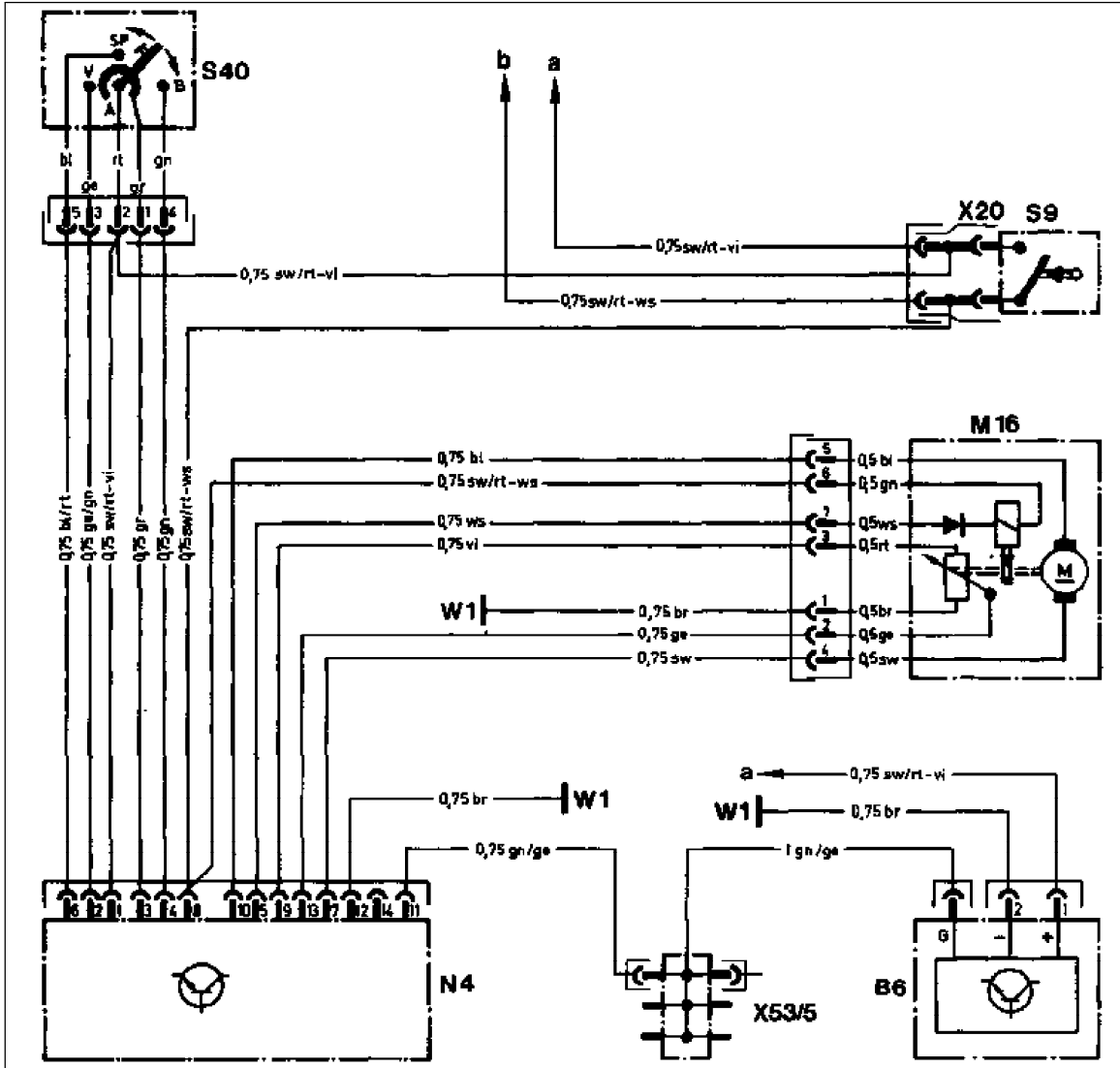

P30.30-0254-59

### Tempomat/cruise control wiring diagram, models 124.125/126/130/131

a	On fuse 5, terminal 15	W1	Main ground (behind instrument cluster)
b	On N7 exterior lamp failure monitoring unit 15	X20	Stop lamp switch intermediate connector (2-pin)
B6	Hall-effect speed sensor	X53/5	Hall-effect sensor multipoint connector, 6-pin (only if speed signal is required for several options)
M16	Cruise control actuator		
N4	CC control module		
S9	Stop lamp switch (2-pin)		
S40	Tempomat/cruise control switch		
	A = Off		
	B = Accelerate		
	SP = Resume		
	V = Decelerate		

### F. Parts ordering note

The parts required for installation are given in the following parts documents

Quantity	Designation	Parts microfiche, group or SA
1	Kit	99