

**ENGINE 601.91, 602.91 up to 1.1.91,
602.96, 603.96 /97 up to 1.5.90**

Modified cylinder head bolts have been installed in order to increase the pretensioning force of the cylinder head bolts.

The modified cylinder head bolts differ from the previous version in having a larger cylinder head contact surface and higher tensile strength.

Marking: code and ribs on bolt head.

A Previous version:

Bolt head diameter 20.7 ± 0.3 mm

Bolt head code 85 or 850

B Modified version:

Bolt head diameter 21.2 ± 0.3 mm

Bolt head code 95 or 950

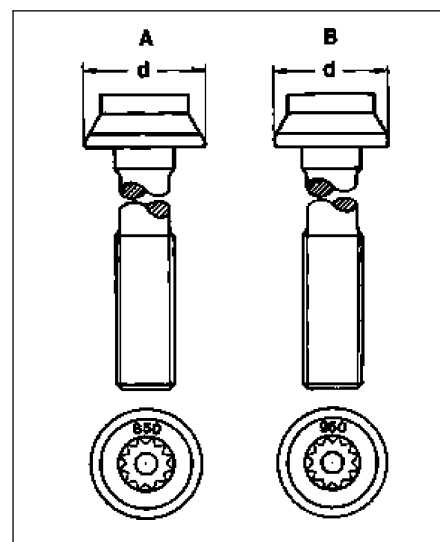

P01.30-0368-02

Implementation of the cylinder head bolts with additional ribs as an identification were phased-in (2 ribs on bolt head, arrows).

Only the modified cylinder head bolts will be available as replacement parts. If it is necessary to replace one bolt on an engine with the previous cylinder head bolts, all of the cylinder head bolts should then be replaced in this case.

It is necessary to measure the length (L) each time before re-using the cylinder bolts, and to replace the bolts if necessary.

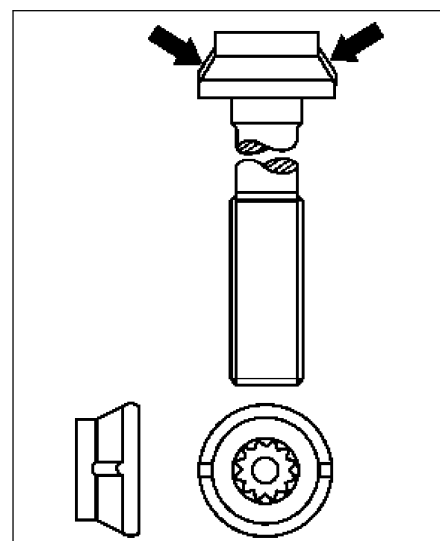

P01.30-0369-02