

### Test values for cylinder head bolts

Number	Designation	Engine 602.982/983		
BE01.30-N-1001-01A	Cylinder head bolt	Thread diameter	M	10
		Length (L) when new	mm	80/102/115
		Length (L)	mm	≤ 83.6/105.6/118.6
		Fig. see		AR01.30-P-5800-03HA

### Cylinder head/cylinder head bolts

Number	Designation	Engine 601, 602 except 602.98, 603		Engine 604, 605, 606
BE01.30-P-1001-04A	Cylinder head bolt	Thread diameter	M	10
		Length (L) when new	mm	80/102/115
		max. length (L)	mm	102/115
		Fig. see		104/117
				-
				AR01.30-P-5800-03HA

### Cylinder head/cylinder head bolts

Number	Designation	Engine 111	Engine 271
BE01.30-P-1001-04B	Cylinder head bolt	Thread diameter	M
		12	10×1.5
		Length (L) when new	mm
		102	165
		Length (L)	mm
		≤ 105	167,5
		Fig. see	
		AR01.30-P-5800-03HA	-

Measure length (L), if length (L) is greater than the maximum permissible dimension, use new cylinder head bolts.

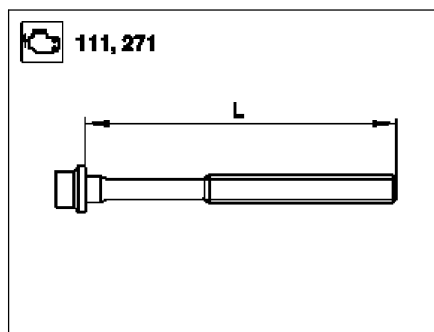

P01.30-2139-01

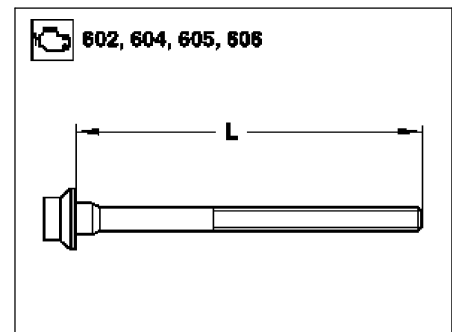

P01.30-0334-01