

01-417 Removal and installation of precombustion chambers

Preceding work:

Mount for engine control removed (30-300).

Nozzle holders removed (07.1-230).

Operation no. of operation texts and work units or standard texts and flat rates

01-5412

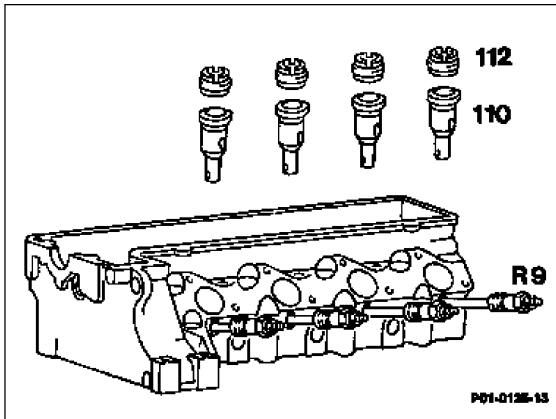

P01-0135-13

Vertical injection
(example engine 601)

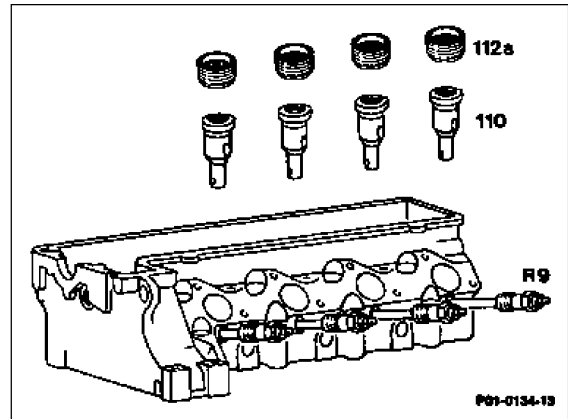

P01-0134-13

Angular injection
(example engine 601)

Glow plugs (R9) _____

screw out, screw in, 20 + 2 Nm (step 1).

Vertical injection:

Threaded ring (112) _____

screw out, screw in, 100 Nm,
pronged wrench 615 589 00 07 00 (step 2).



When screwing in or out assure that the pin wrench is seated in the grooves in the threaded ring.

Angular injection:

Threaded ring (112a) _____

screw out, screw in, 130 Nm, splined wrench
603 589 00 09 00 (step 3).

Precombustion chamber (110) _____

knock out, install, impact puller
602 589 00 33 00 and check (steps 4, 6).

Precombustion chamber mounting bore _____

in cylinder head, clean, check and cover
(step 5).

Note

Install precombustion chamber so that the lug on the collar of the precombustion chamber is located in the recess in the cylinder head.

Note

Refinish precombustion chamber sealing surface if required (01-410).

Precombustion chamber survey

Engine	601.91 1) 602.91 1) 603.91 1)	603.96 up to 9/88	601.91 (CH) 2) as of 10/86 up to 8/88	602.961 up to 09/88	601.91 2) 602.91 2) 603.91 2) as of 09/88	602.961 as of 09/88 602.962 Standard 602.96 (A) as of 1989 603.96 (A) as of 09/88	603.962 2) 603.970 2) (USA) as of 09/88 603.9713) as of 09/92 as of 04/94 602.96/ 603.966) 603.976)
Code	601/07 or 17	601/09 or 23	601/14	601/15	601/25 or 295)	601/26 601/364)	601/30 601/363)
Version	A	A	B	B	C	C	C
Combustion neck OD (mm)	14	15	14	15	14	15	15

- 1) Without exhaust gas recirculation
- 2) With exhaust gas recirculation starting 02/89
- 3) As of 02/92 (USA), ECE as of 01/93, certain burner bores countersunk 4°, prechamber volume increased to 11.37 cm³
- 4) Engine 602.96 as of 05/92 with EGR, certain burner bores countersunk 4°
- 5) As of 03/92 with EGR
- 6) As of 04/94 all turbocharged engines, (standard prechamber of 11.37 cm³) prechamber volume and certain burner bores countersunk 4°

Differentiation, vertical and angular injection

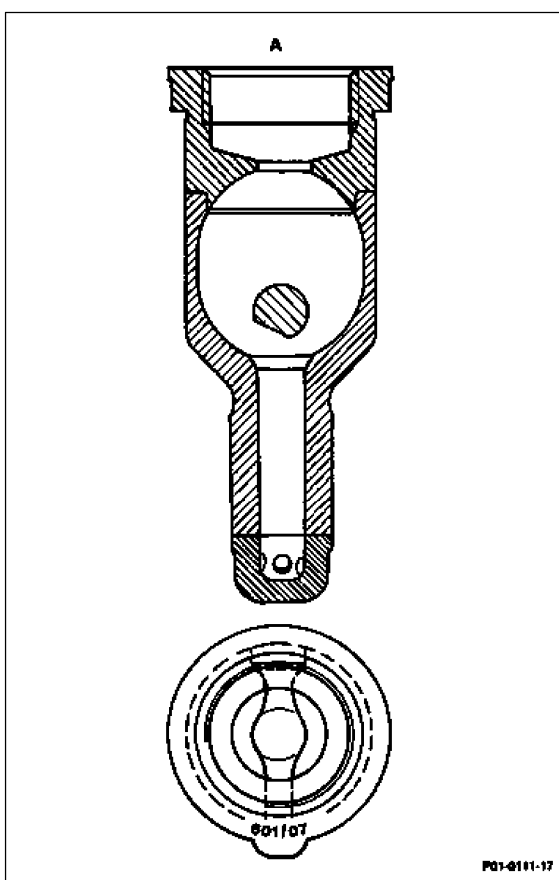

P01-0111-17

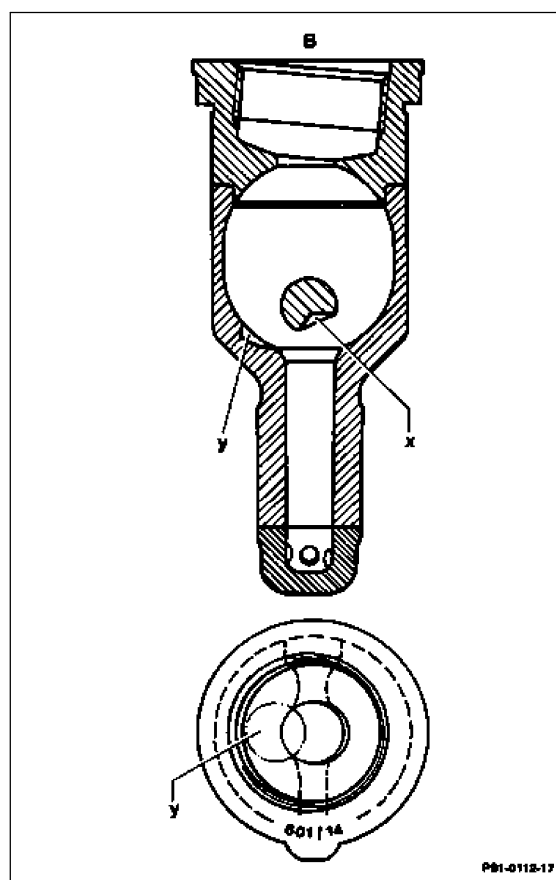

P01-0112-17

A Precombustion chamber, vertical injection

Code 601/07, 601/17, 601/09, 601/23

B Precombustion chamber angular injection,
inclined 5°

Code 601/14, 601/15

x Cone
y Recess

C Precombustion chamber, angular injection
Inclined 5°, turned 180°
Code 601/25, 601/26, 601/30/36

x Cone
y Recess

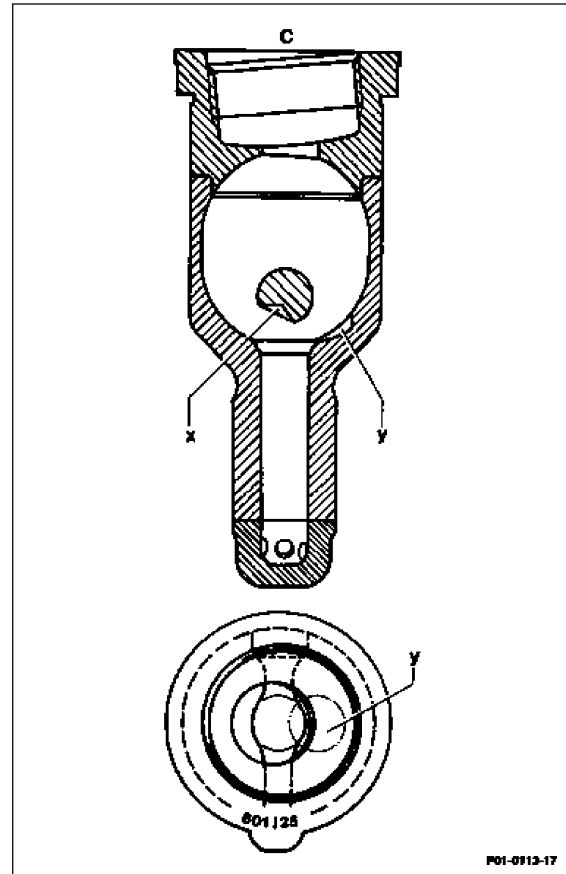

P01-0113-17

Differentiation, combustion neck diameter

The individual combustion neck diameters (d) differ
on naturally aspirated engines and turbo-engines.

d=14 mm naturally aspirated engines
d=15 mm turbo-engines

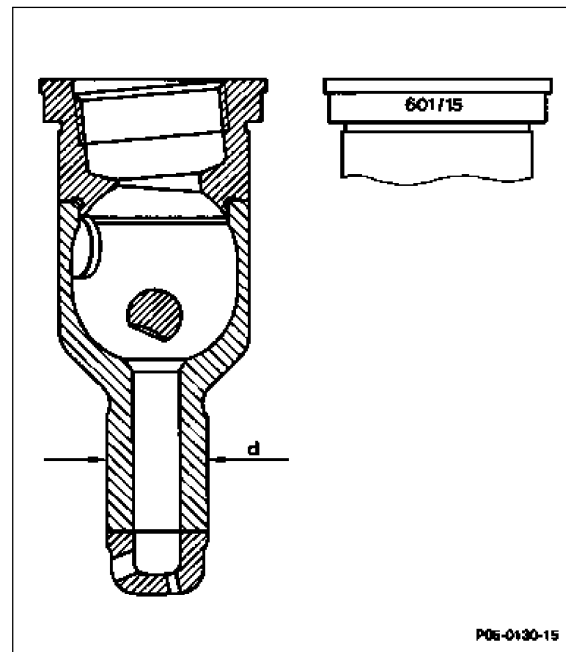

P05-0130-15

Differentiation, combustion bores

6 combustion bores with different diameters are located in different planes and at different angles in the bottom section of the precombustion chamber (combustion neck).

The injection angle is 180°, on engine 602.61, 603.971 - 164°.

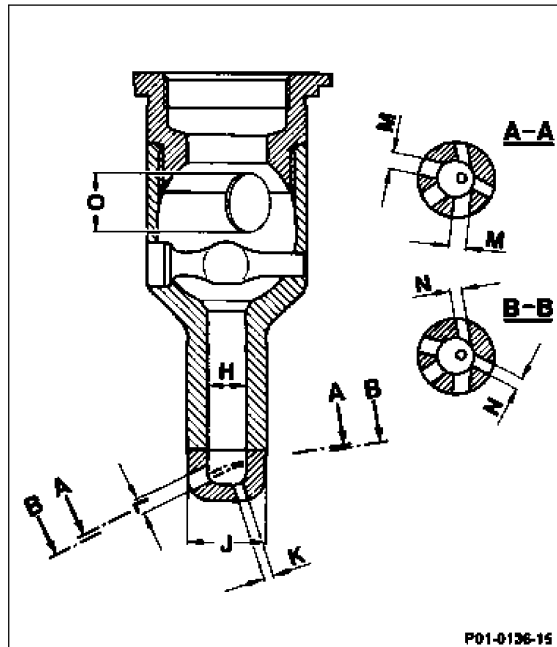

P01-0136-15

P01-0136-15

Combustion bore diameters (dia. in mm)

Precombustion chamber code	601/07 or 17	601/09 or 23	601/14/25	601/15/26	601/30
H Firing duct	7.0	7.0	7.0	7.0	7.0
J Combustion neck	14.0	15.0	14.0	15.0	15.0
K Combustion bore	1.5	1.5	1.8	1.8	1.8
L Combustion bore	3.2	3.2	3.0	3.0	3.0
M Combustion bore	3.0	3.0	3.0	3.0	3.0
N Combustion bore	2.0	2.0	2.5	2.5	2.5
O Bore for glow plug	10.0	10.0	10.0	10.0	10.0

Tightening torques

Nm

Glow plugs	20+2
Threaded ring, vertical injection	100
Threaded ring, angular injection	130

Special tools

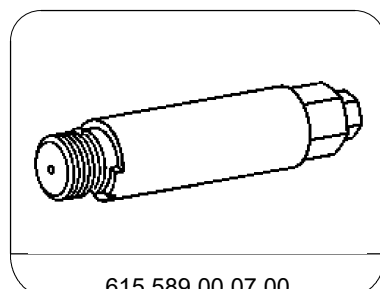

615 589 00 07 00

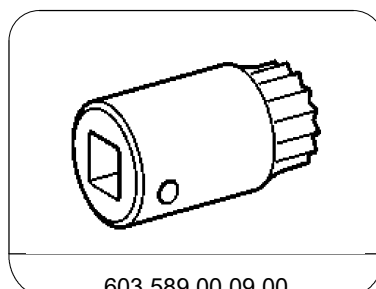

603 589 00 09 00

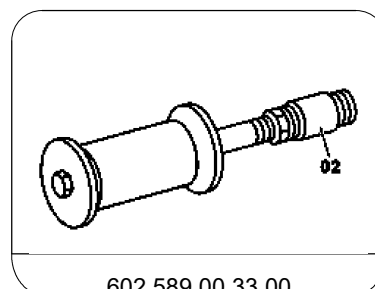

602 589 00 33 00

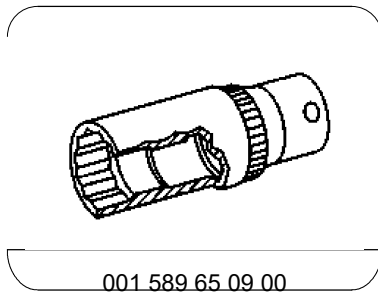

001 589 65 09 00

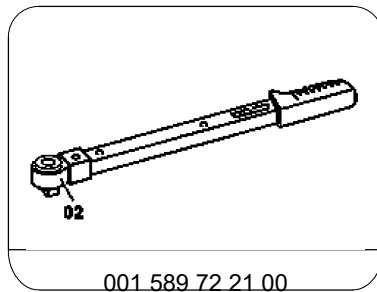

001 589 72 21 00

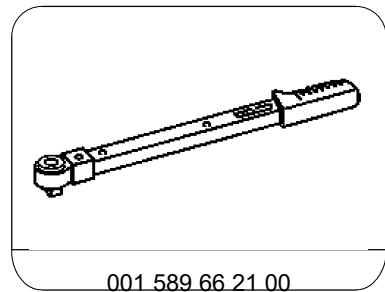

001 589 66 21 00

Removal, installation

- 1 Screw out glow plugs (R9).

Installation note

Tightening torque 20 + 2 Nm.

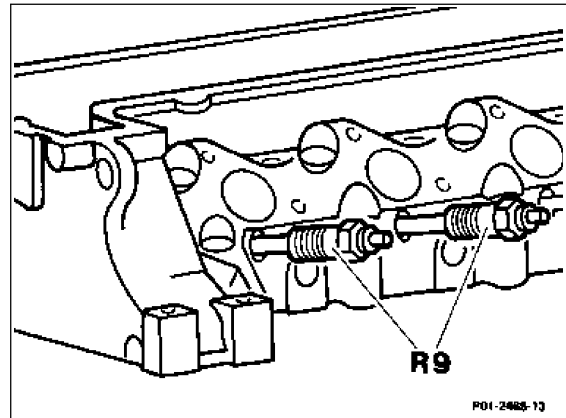

P01-2465-13

P01-2465-13

Vertical injection:

- 2 Screw threaded end (03) of pin wrench 615 589 00 07 00 into threaded ring of precombustion chamber.

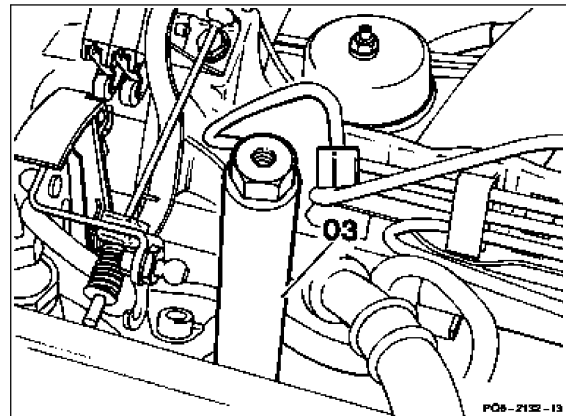

P05-2132-13

P05-2132-13

- 2.1 Slide sleeve (02) of pin wrench over threaded end and insert into grooves in threaded ring.



The sleeve must be seated tightly in the grooves of the threaded ring.

- 2.2 Counter sleeve (02) with hex. head bolt (01).

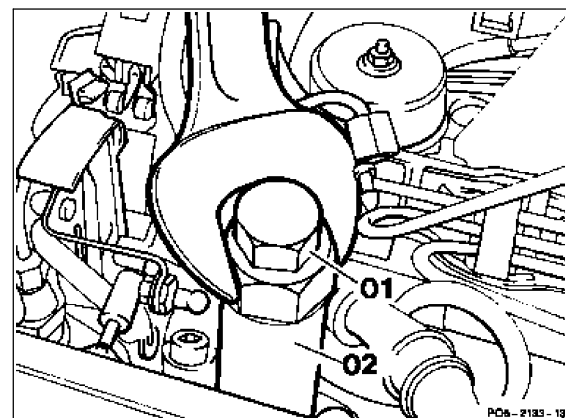

P05-2133-13

P05-2133-13

- 2.3 Screw out threaded ring with open-end wrench on hex. end of sleeve (02).

Installation note

Oil threaded ring.

Tightening torque 100 Nm.

Angular injection:

3 Screw out threaded ring with splined wrench 603 589 00 09 00.

Installation note

Oil threaded ring.

Tightening torque 130 Nm.

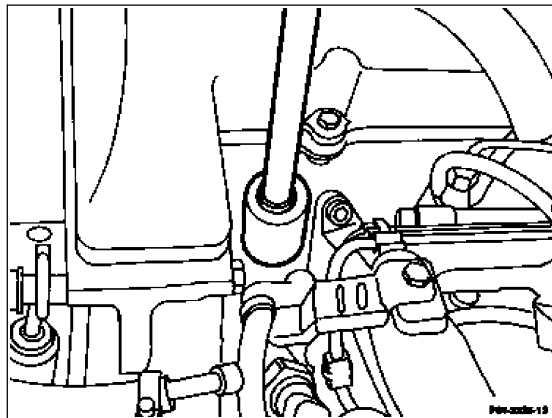

P01-2235-13

4 Screw impact puller 602 589 00 33 00 into precombustion chamber and knock out precombustion chamber.

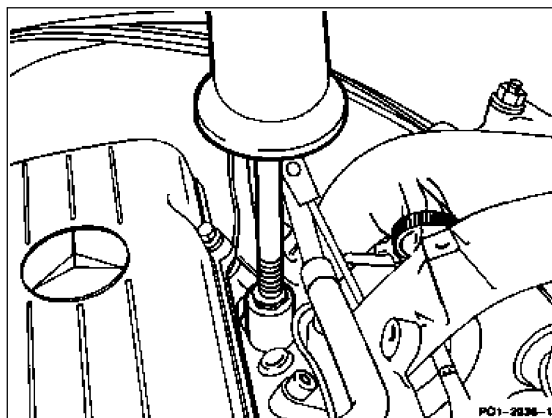

P01-2236-13

Installation note

Insert precombustion chamber into mounting bore so that lug on collar of precombustion chamber fits in recess in cylinder head (arrows).

5 Clean mounting bore for precombustion chamber in cylinder head, check and cover.

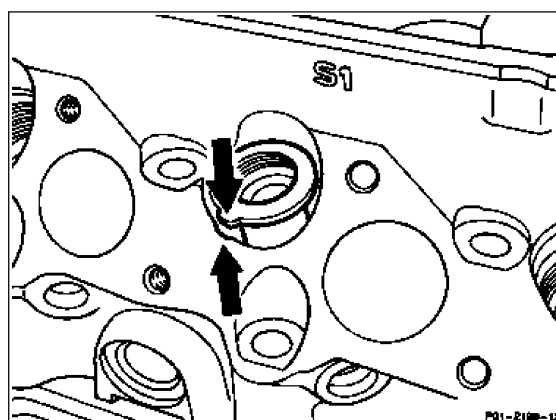

P01-2199-13

Note

Refinish precombustion chamber sealing surface if required (01-410).

6 Check precombustion chambers.

Note

The spherical pin must not be burned or scaly. If the combustion tips are burned or cracked in the bottom section of the precombustion chamber, check the following:

1. Oil level at oil temperature of approx. 80°C. If the quantity of oil in the oil pan is too high, correct oil level.
2. Check piston vacuum pump for damage or replace vacuum box on injection pump.

Which of the two components is unfit for use can be seen on the vacuum lines (blackened with oil).

7 Install in opposite order.