

Modification notes

22.9.99	Supersedes SI05/95 dated 14.2.96		
---------	----------------------------------	--	--

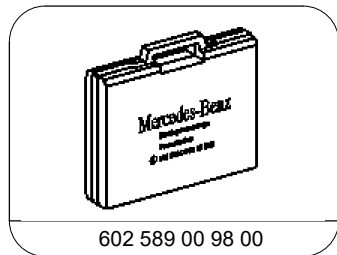

602 589 00 98 00

Case

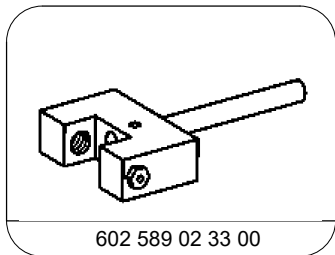

602 589 02 33 00

Chain separating tool

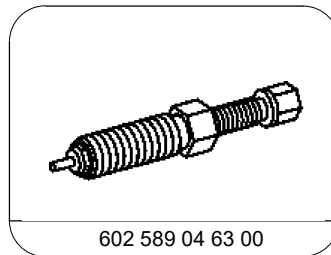

602 589 04 63 00

Thrust spindle

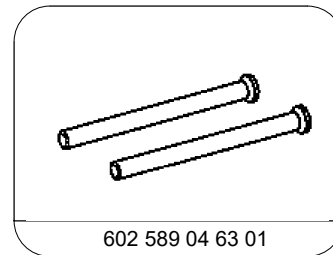

602 589 04 63 01

Thrust pins

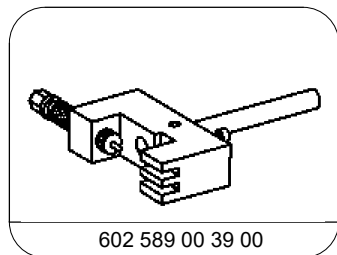

602 589 00 39 00

Riveting tool

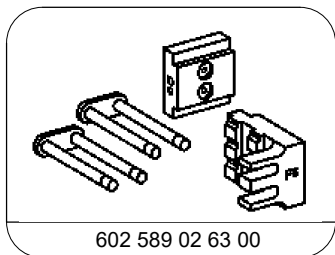

602 589 02 63 00

Assembly inserts

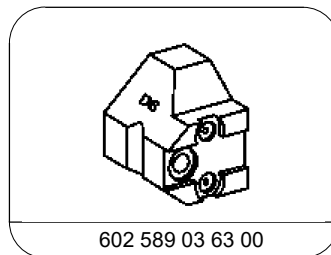

602 589 03 63 00

Thrust piece

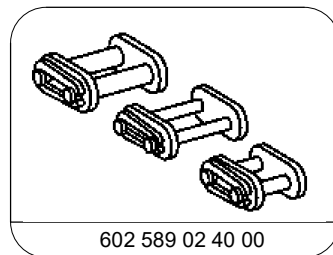

602 589 02 40 00

Assembly links

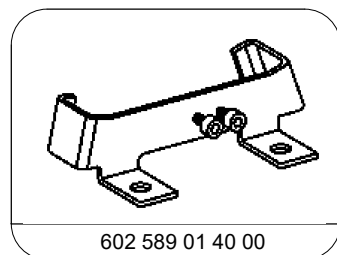

602 589 01 40 00

Holding device

Separating

- 1 Attach holding device 602 589 01 40 00 to cylinder head with screws (supplied).
- 2 Cover over chain housing with a clean cloth.

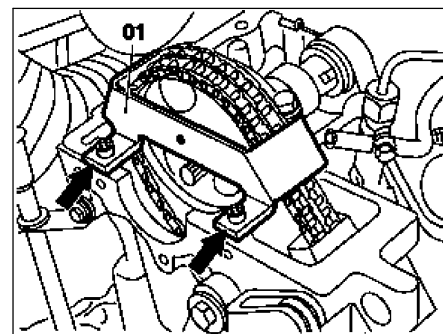

P05.10-0262-01

- 3 Screw thrust spindle (02) 602 589 04 63 00 together with thrust pin 602 589 04 63 01 into chain separating tool (03) 602 589 02 33 00.
- 4 Position chain separating tool (03) against timing chain.
- 5 Screw in thrust spindle (02) sufficiently until thrust pin is positioned against the left (looking in direction of rotation of engine) timing chain pin of a chain link.
- 6 Press out thrust pin of timing chain by screwing in thrust spindle (02a).

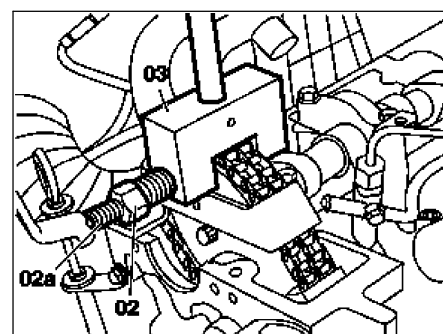

P05.10-0263-01

- 7 Unscrew thrust spindle (02), take off chain separating tool (03).
- 8 Pull removed chain pin (1) out of chain separating tool (03).

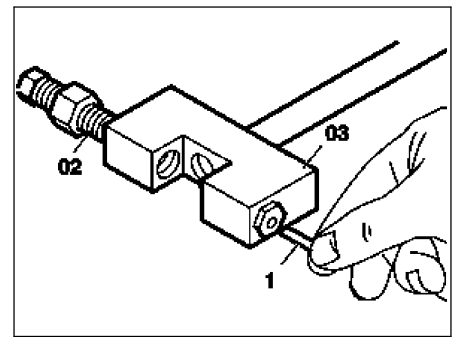

P05.10-0271-01

Inserting

- 9 Connect new timing chain (5) to the old timing chain (4) with the connecting link (04) 602 589 02 40 00 and secure.
- 10 Rotate engine at crankshaft in direction of rotation of engine and draw in new timing chain (5).
- 11 Remove connecting link (04), take off old timing chain (4).

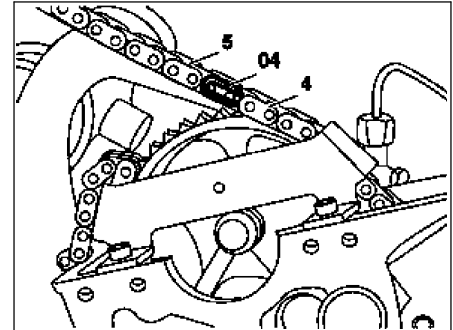

P05.10-0268-01

ⓘ It is essential to remove the connecting link (04). It is only an assembly aid and is not suitable for engine running.

Riveting

- 12 Insert center plate (2) into the timing chain and fix in place with the assembly link  (05).

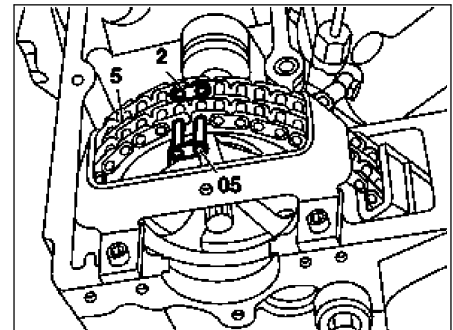

P05.10-0266-01

- 13 Insert assembly inserts (F5 and D9) into riveting tool (06), screw on.

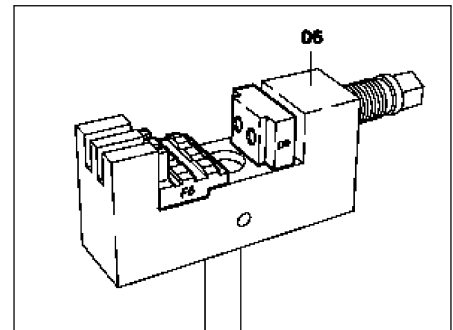

D05.10-0051-01

- 14 Push riveted link (3) into new timing chain.

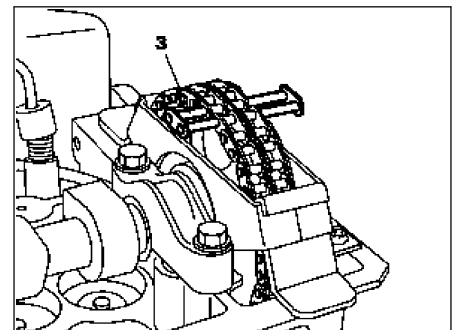

D05.10-0052-01

- 15 Fit riveting tool onto timing chain.
- 16 Turn spindle and press in riveted link (3) as far as the stop.
- 17 Take off riveting tool.

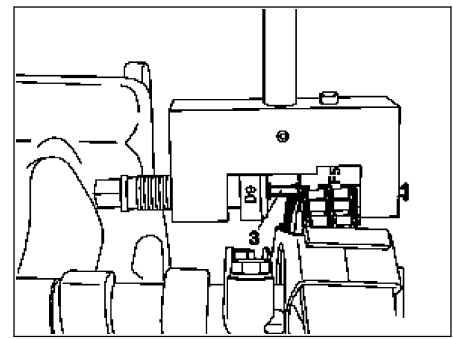

D05.10-0053-01

- 18 Insert riveting inserts (D8) and (F1) into riveting tool (06).

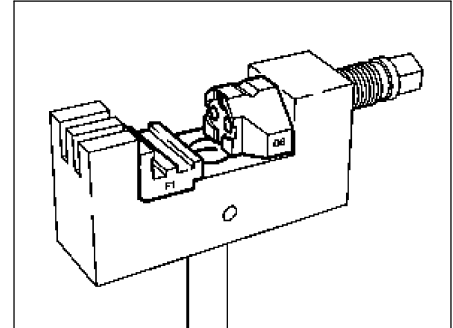

D05.10-0055-01

- 19 Insert outer plate of riveted link into riveting tool (magnetic fixture)

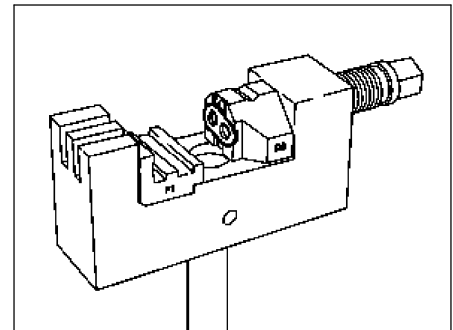

D05.10-0054-01

- 20 Press on outer plate

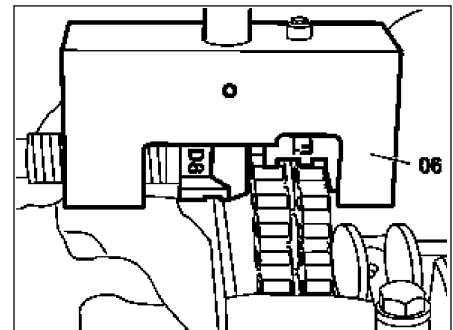

P05.10-0265-01

- 21 Turn over riveting insert (D8)
- 22 Rivet pins of riveted link individually

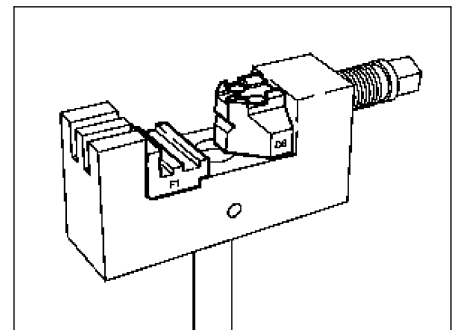

D05.10-0056-01

23 Inspect riveting (arrows), re-rivet if necessary.

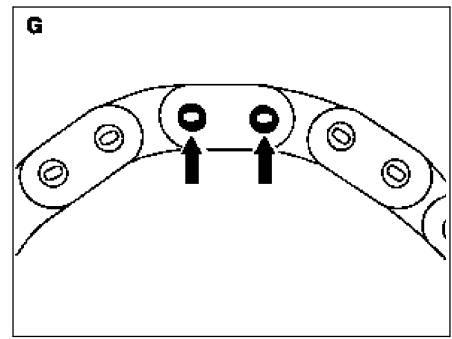

P05.10-0213-01