

## 03-330 Removal and installation of radial ball bearing in crankshaft

Preliminary jobs:

Transmission removed (26-020).

Clutch removed (25-050).

Operation No. of operation texts and operation values or standard texts and flat rates \_\_\_\_\_ 03-8400

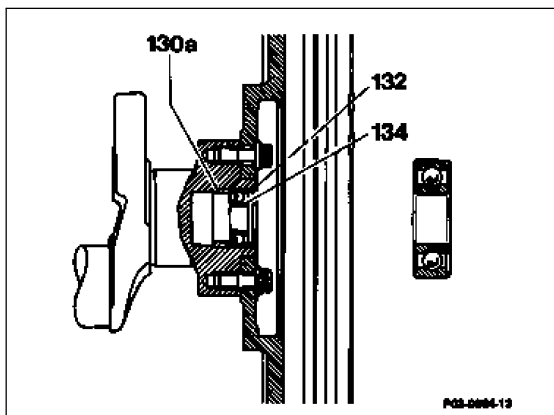

Radial ball bearing (134)  
and locking ring (132)

remove, install. Use internal puller 000 589 25 33 00, countersupport 000 589 33 33 00. Renew locking ring (132) and radial ball bearing (134) and coat with glue 002 989 94 71. Knock into crankshaft with suitable punch on outer race (item 1).

Spacer ring (130a)

knock in flush (item 1).

### Note

For reasons of standardization the same radial ball bearing (134) as in engine 102 is installed. The ball bearing is sealed on both sides with Viton cover discs and cemented into the crankshaft.

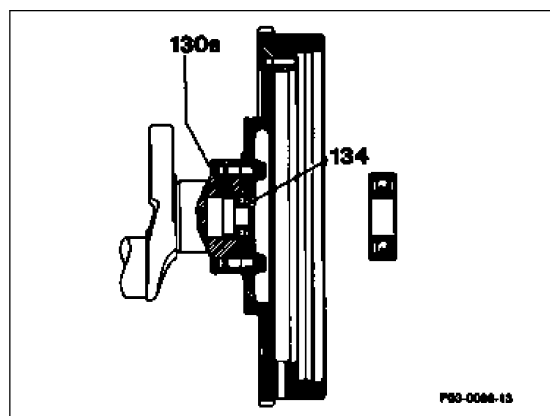

130 a Spacer ring

### Production breakpoint: 02/84

Model	Engine	Engine end no.		Vehicle ident end no.	
		manual transmission	automatic transmission	A	F

201.122	601.911	005761	054049	003671
	601.921	001201	066801	009046

### Locking ring for ball bearing in crankshaft, engines 601.911/921

Starting 07/84 a locking ring (132) is installed for securing the ball bearing (134) in the crankshaft (ball bearing was previously cemented in). Moreover the spacer ring (130a) is narrower.

For repair these parts can also be installed in vehicles produced earlier.

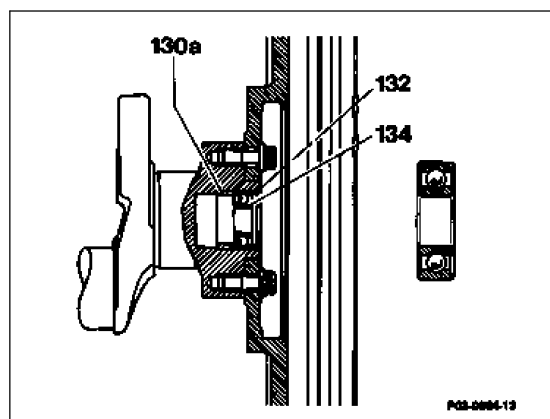

### Replacement parts

Designation	Part no.
Spacer ring	102 031 02 51
Locking ring	102 031 01 33
Ball bearing	115 980 01 15

### Production breakpoint: 07/84

Model	Engine	Engine end no.		Vehicle ident end no.	
		manual transmission	automatic transmission	A	F
201.122	601.911	028649		104984	022462
	601.921	001737		*	028653

\* not registered

### Adhesive

Loctite 241	002 989 94 71
-------------	---------------

### Special tools

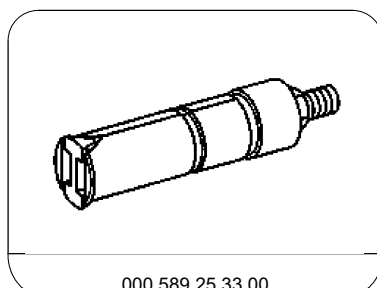
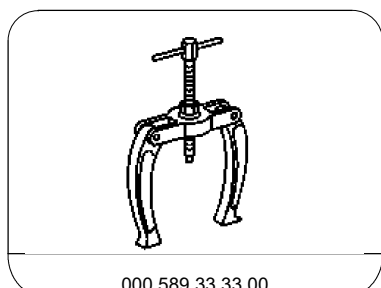

## Removal, installation

---

1 Pull radial ball bearing out of crankshaft together with locking ring, use internal puller 000 589 25 33 00 and countersupport 000 589 33 33 00.

### Installation note

Knock in spacer ring flush.

Coat new ball bearing with cement 002 989 94 71 and knock into crankshaft with suitable punch on outer race.

2 Install in opposite order.

