

03-318 Checking and reconditioning crankshaft

Preliminary jobs:
Crankshaft removed.

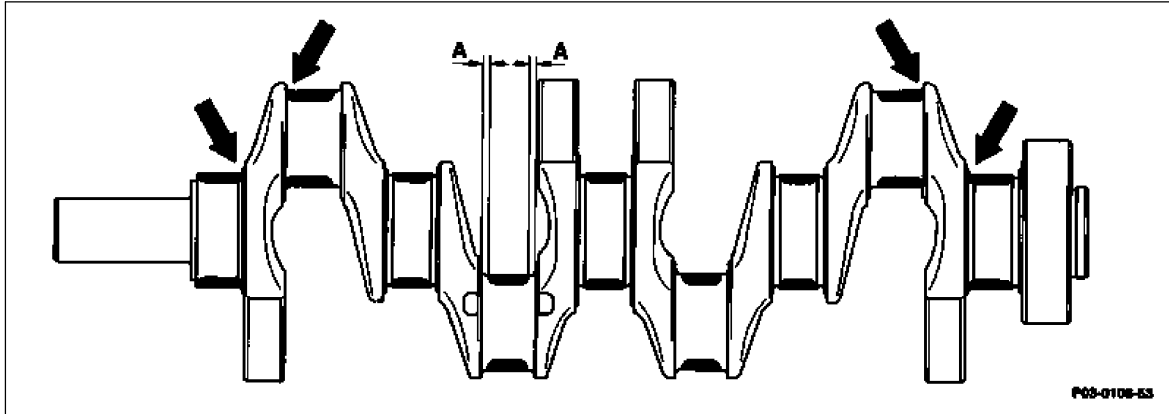

P03-0108-53

Crankshaft	clean
Crack test	perform; apply fluorescent powder (magnaflux) or use penetration method.
Hardness test (scleroscope hardness)	perform with impact hardness tester 000 589 20 21 00.
Distance (A = 5 - 6 mm)	when hardening journals without hardened fillets, maintain distance A between hardened runout and fillet radius.
Journals	can be hardened inductively or with flame.



Harden journals with hardened fillets (arrows) inductively only.

Data

Crankshaft normal dimensions and repair stages	Crankshaft bearing journal dia.	Fitted bearing		Connecting rod bearing journal dia.	Connecting rod bearing journal width	
		Associated thickness of thrust washers	Width of journal			
Standard dimension	57.940	2.15	26.52 ¹⁾	24.53 ²⁾	47.940	27.96
	57.965		26.50	24.50		
1st repair stage	57.700	2.20	26.62 ¹⁾	24.63 ²⁾	47.965	28.04
	57.715		26.60	24.60		
2nd repair stage	57.450	2.25	26.72 ¹⁾	24.73 ²⁾	47.700	- 28.30
	57.465		26.70	24.70		
3rd repair stage	57.200	2.35	or		47.450	
	57.215		or	26.92 ¹⁾	24.83 ²⁾	
4th repair stage	56.950	2.40	26.90	24.90	47.200	
	56.965		or	or		
			27.02 ¹⁾	25.03 ²⁾	46.950	
			27.00	25.00	46.965	

1) Up to 06/84

2) Starting 07/84

Test values

Permissible deviation of crankshaft main and rod journals in mm	0.005	
Permissible conicity of crankshaft main and rod journals in mm	0.01	
Permissible roughness of crankshaft main and rod journals (Ra) in mm	0.005 – 0.015	
Permissible deviation of flywheel flange from true in mm	0.02	
Permissible axial runout of fitted bearing in mm	0.02	
Fillet radii in mm	on crankshaft main journals	2.5 – 3.0
	on rod journals	3.0 – 3.5
Permissible deviation of crankshaft main journals when mounted in outer crankshaft bearing journals in mm	Journal II, IV	0.16
	Journal III	0.25
Scleroscope hardness of crankshaft main and rod journals	55 – 74	
Permissible unbalance of crankshaft	10 cmg	

Special tool

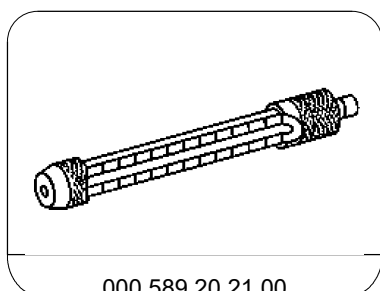

000.589.20.21.00

Note

When testing and reconditioning crankshafts, proceed in sequence shown in diagram below.

A. Testing, grinding

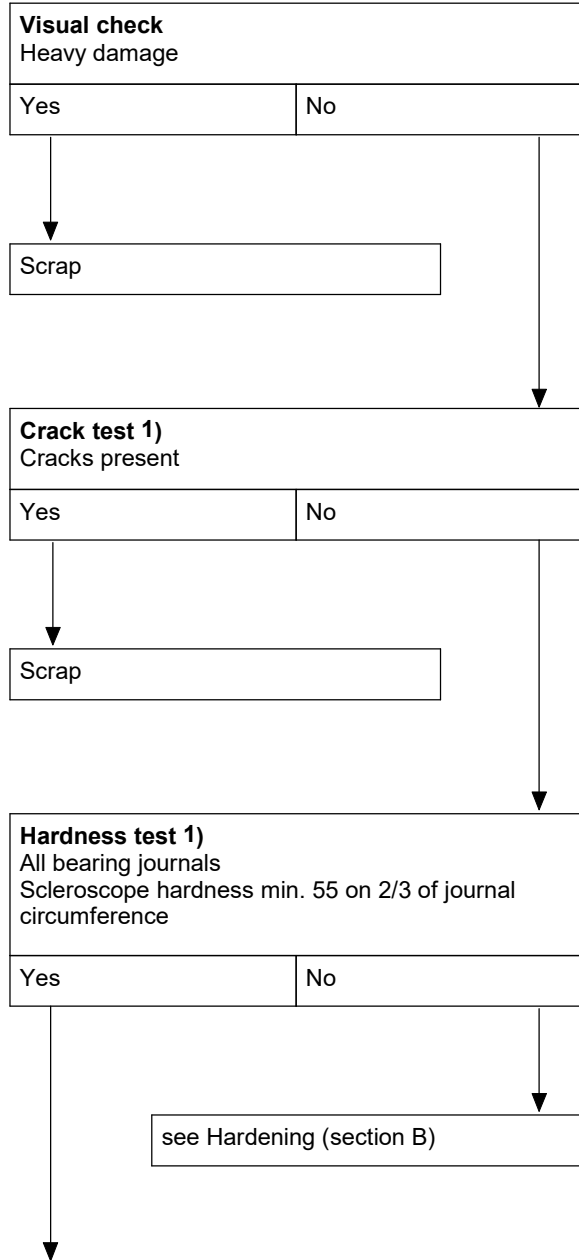

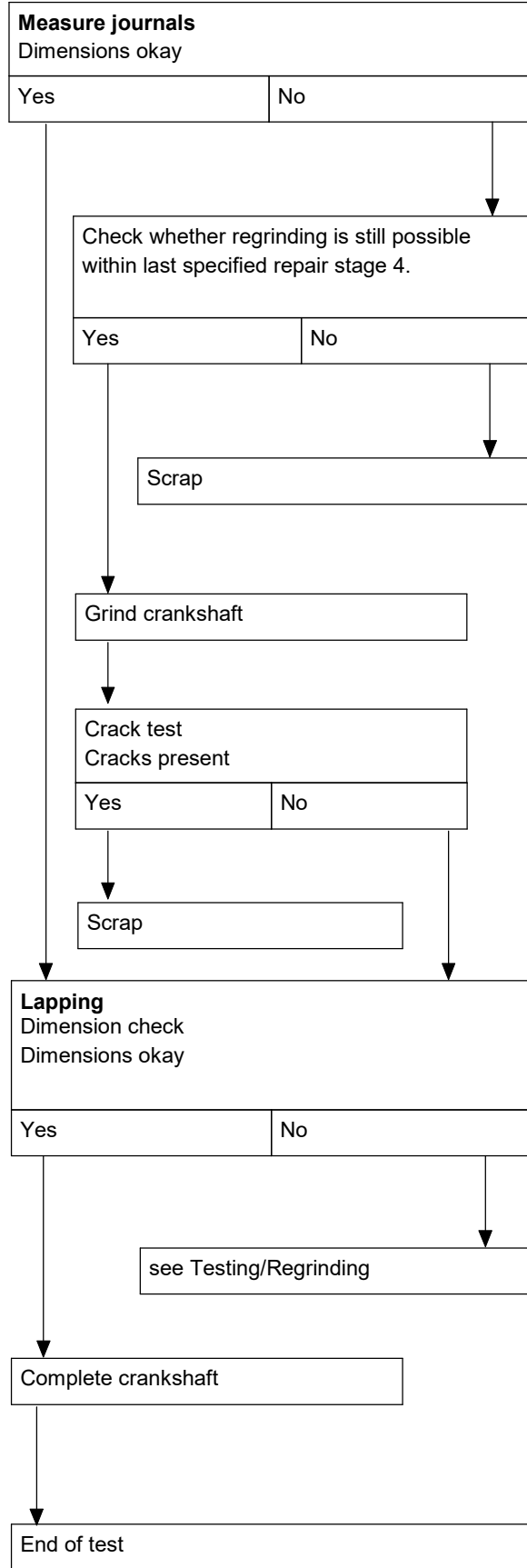

B. Hardening

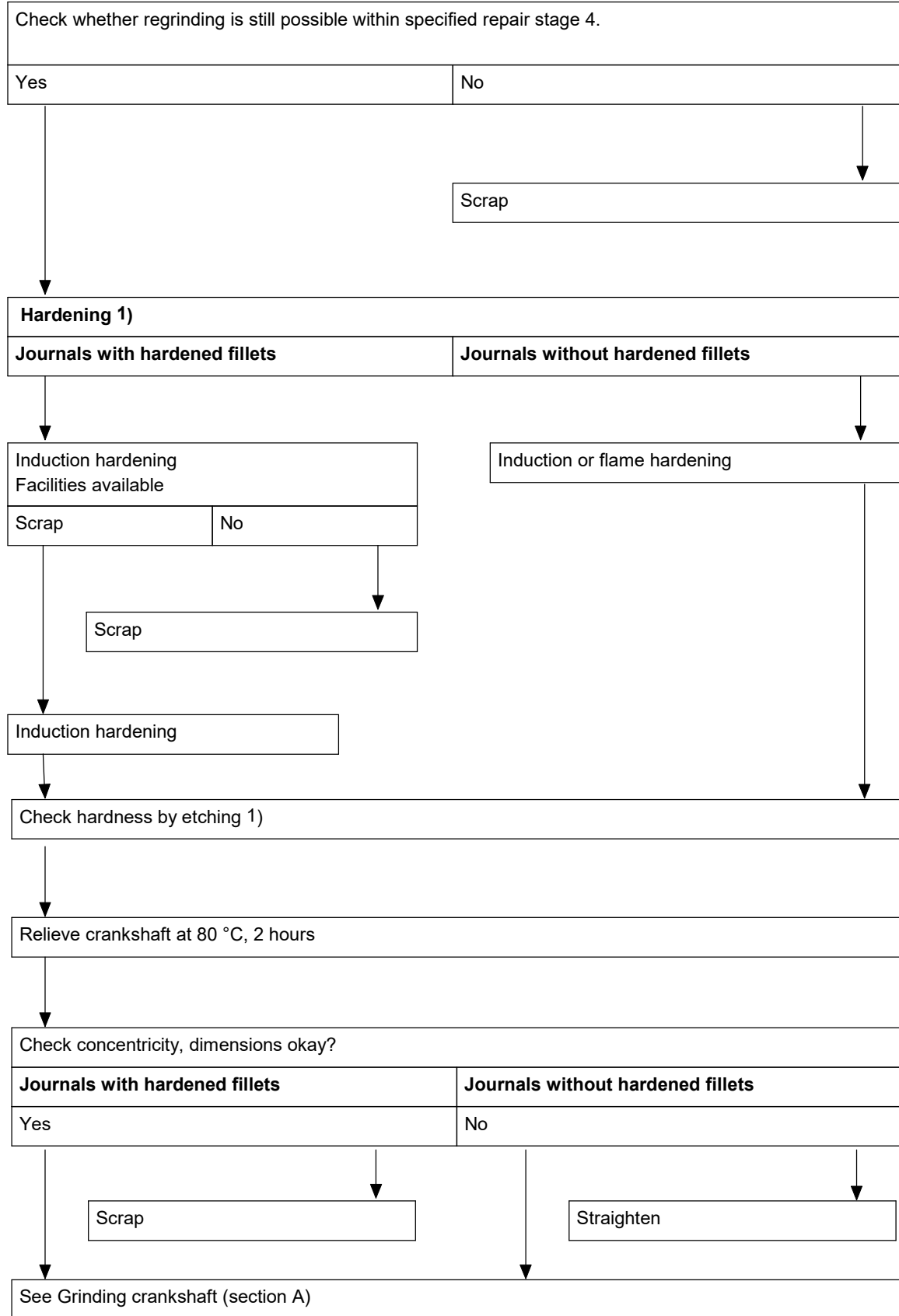

Crack test

Clean crankshaft. Bearing journals should be free of oil and grease.

Magnetize crankshaft and apply fluorescent powder (magnaflux).

A color penetration method may also be used (immersion in bath or using spray can).

Agent:

Paint or fluorescent powder,
cleaning agent,
developer

Hardness test

Test hardness with impact hardness tester
000 589 20 21 00 (scleroscope hardness).

The minimum hardness of 55 should be present on
2/3 of journal circumference.

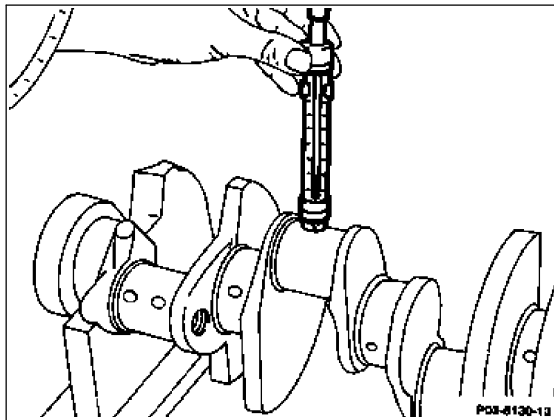

P03-5130-13

Hardening

Journals without hardened fillets can be hardened inductively or flame-hardened. Journals with hardened fillets (arrows) must always be hardened inductively.

If this is not possible, scrap crankshaft.

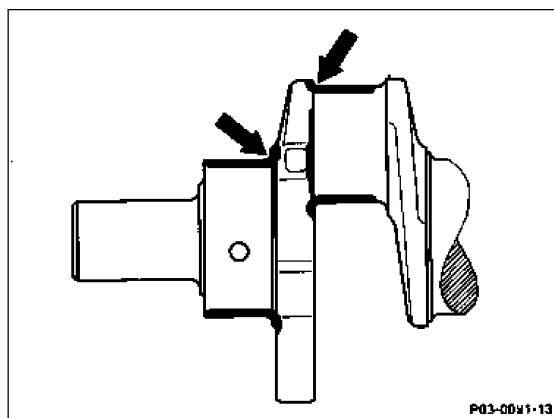

P03-0091-13

Checking hardening results

To achieve perfect hardening check adjustment of hardening equipment using microsections.

These can be obtained from scrapped crankshafts hardened for testing purposes.

Check hardening by etching the journal surface with a 2 % solution of alcoholic nitric acid (HNO₃).

Dark spots should not appear on the journal surface.

Unhardened fillets will become dark.

On the other hand hardened fillets should be as bright as the surface of the journals.

We recommend comparing the etching test with a journal tested via metallographic microsection.

Then carefully wash off nitric acid with alcohol.

Corrosion protection

Crankshafts which are not installed again immediately should be lubricated with engine initial operation oil (SAE 30).