

Inspection data of conrod bolts

Number	Designation	Engine 601, 602 except 602.98, 603 except 603.970 up to 11/90		Engine 601, 602 except 602.98, 603 except 603.970 as of 12/90 - 10/92		Engine 601, 602 except 602.98, 603 as of 11/92	
		Thread Ø	M				
BE03.10-P-1001-03C	Conrod bolt (straight stretch shank)	Thread Ø	M	-	9X1	9X1	
		Length (L)	when new	mm	-	51.7	51.7
			max.	mm	-	52.9	52.9
		Stretch shank Ш	New	mm	-	8.5	-
			min.	mm	-	8.2	-
See figure			-	AR03.10-P-6111-01AW	AR03.10-P-6111-01AW		
BE03.10-P-1002-03C	Conrod bolt (stretch bolt)	Thread Ø	M	9X1	-	-	
		Length (L)	when new	mm	51.7	-	-
			max.	mm	-	-	-
		Stretch shank Ш	New	mm	7.3	-	-
			min.	mm	7.1	-	-
See figure			AR03.10-P-6111-01AW	-	-		

1 Inspect minimum stretch shank Ø (c) or length (L). If the measurement obtained is less than the minimum stretch shank Ø or greater than the maximum length, replace conrod bolt.

ⓘ Only conrod bolts of the same type must be fitted to an engine because of the different weight.

Stretch shank bolt installed, engine 603.970 up to 08/1990, engine 601, 602, 603 except 603.970 up to 11/1990

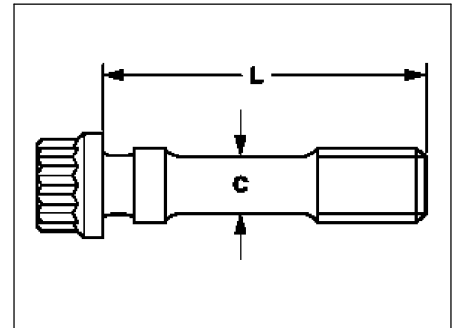

P03.10-0258-01

Straight stretch shank bolt installed as of 09/1990 in engine 603.970 up to 10/1992 as of 12/1990 in engines 601, 602, 603 except 603.970 up to 10/1992

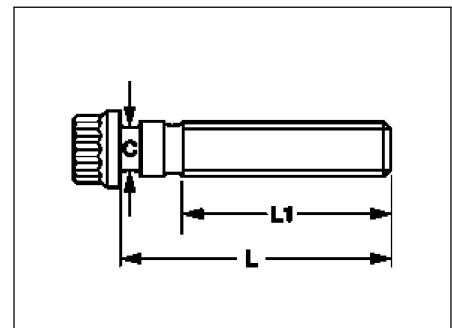

P03.10-0259-01

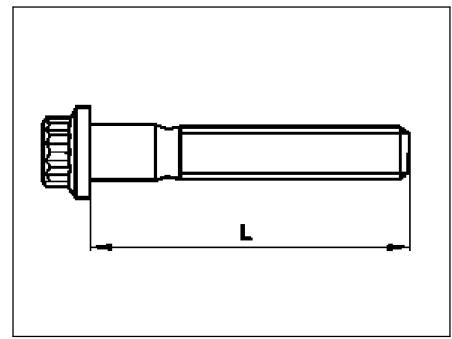

P03.10-0225-01