

## 03-350 Removal and installation of crankshaft sprocket

### Preliminary jobs:

Timing case cover removed (01-210).

Oil pan removed (01-310).

Vehicles with level control:

Drive for oil pump removed (05-437).

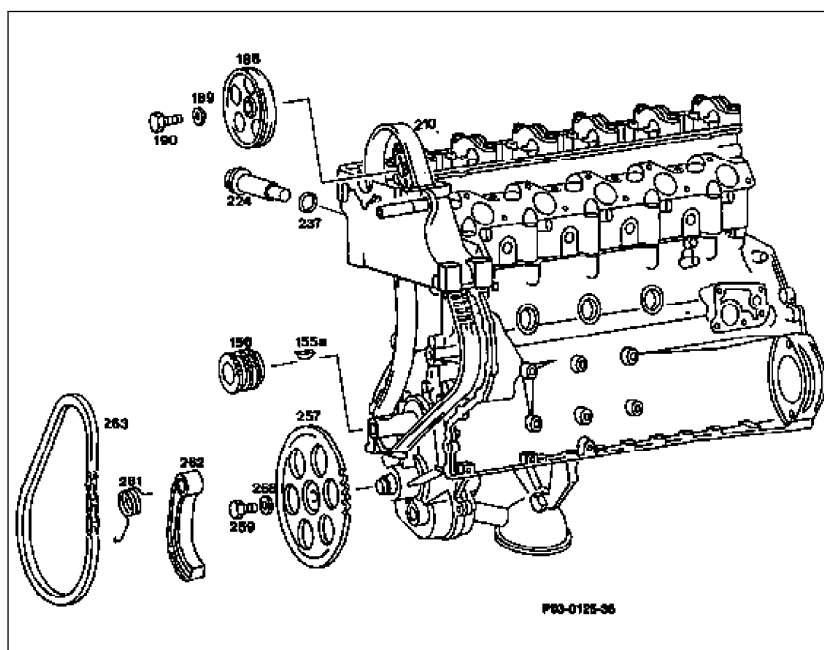

- Tensioning bracket (262) \_\_\_\_\_ remove together with torsion spring (261), install (items 1, 17).
- Oil pump sprocket (257) \_\_\_\_\_ screw out hex. head bolt (259) and remove together with washer (258) (item 2).
- Chain for oil pump drive (263) \_\_\_\_\_ remove (item 3).
- Chain tensioner (224) \_\_\_\_\_ remove, install. Replace sealing ring (237) (05-310) (items 4, 14).
- Camshaft sprocket (188) \_\_\_\_\_ mark in relation to timing chain (210), screw out retaining bolt (190) together with washer (189) and remove camshaft sprocket (items 6 - 8).

### Note

Observe differences in bolts.

- Crankshaft sprocket (156) \_\_\_\_\_ mark in relation to timing chain (210) (item 5).
- Crankshaft sprocket (156) \_\_\_\_\_ pull off with puller 601 589 07 33 00 and check retaining wedge (155a), renew, if required (items 9 - 10).
- Crankshaft sprocket (156) \_\_\_\_\_ renew, transfer color code and knock onto crankshaft with installation punch 116 589 07 15 00 while paying attention to retaining wedge (155a) (items 11 - 12).
- Camshaft sprocket (188) \_\_\_\_\_ position on mark, install timing chain and tighten. Remove hex. head bolts (190) and washers (189). Hex. head bolt 65 Nm, 12-point bolt 25 Nm/90° rotation angle (item 13).

Crankshaft \_\_\_\_\_ continue to turn and check adjustment markings at TDC position (item 15).

Oil pump sprocket (257) \_\_\_\_\_ install with chain for oil pump drive (263) and tighten hex. head bolt (259), 25 Nm (item 16).

Engine \_\_\_\_\_

**Note**

Install chain sprocket so that arch points toward oil pump.

allow to run and check for leakage (item 18).

**Bolt for camshaft sprocket**

Starting 11/88 the bolt for mounting the camshaft sprocket was changed from an M 10 bolt to an M 11 stretch bolt (see 05-220).

**Tightening torques and angles of rotation**

Nm  
Angle of rot.

Hex. head bolt for camshaft sprocket	65	-
12-point bolt for camshaft sprocket	25	90°
Hex. head bolt for oil pump sprocket	25	-

**Special tools**

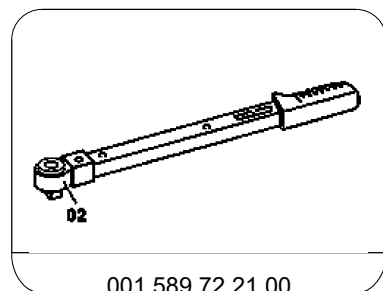
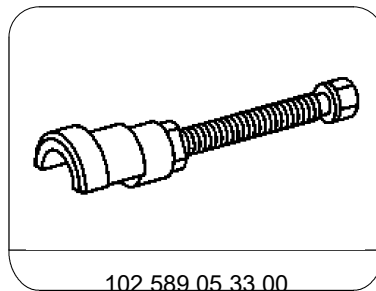
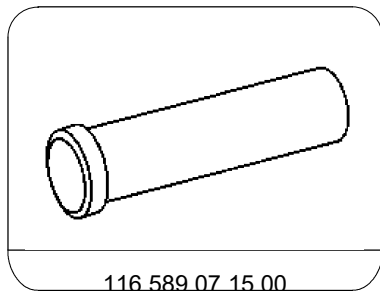

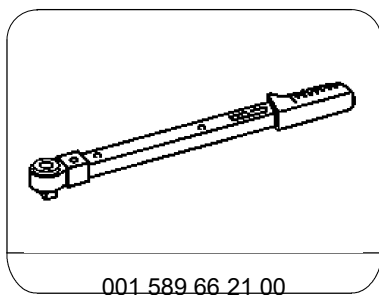

## Removal

- 1 Remove clamping bracket (262) and torsion spring (261).
- 2 Remove hex. head bolt (259) with washer (258) and remove oil pump sprocket (257).
- 3 Remove chain for oil pump drive (263).
- 4 Remove chain tensioner (05-310).

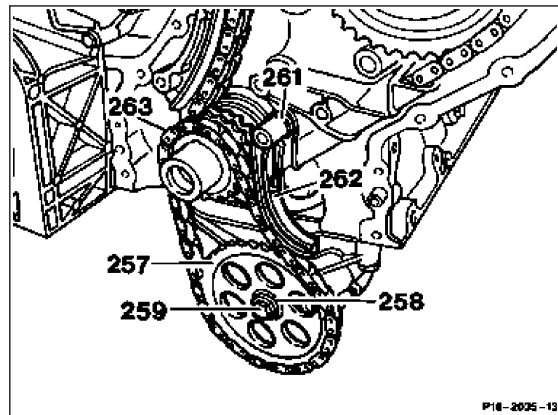

- 5 Mark position of timing chain and crankshaft sprocket in relation to one another.

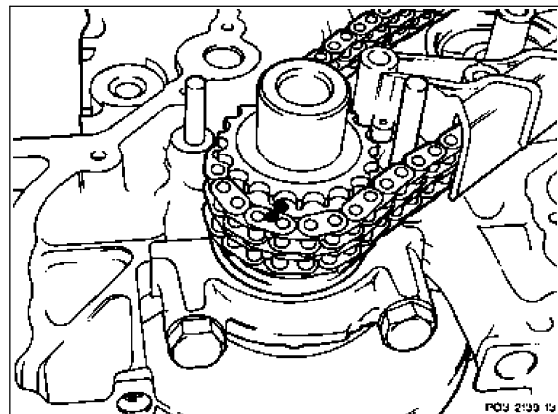

- 6 Mark position of timing chain and camshaft sprocket in relation to one another.
- 7 Screw out hex. head bolt and remove with washer.
- 8 Remove camshaft sprocket and allow timing chain to sag.

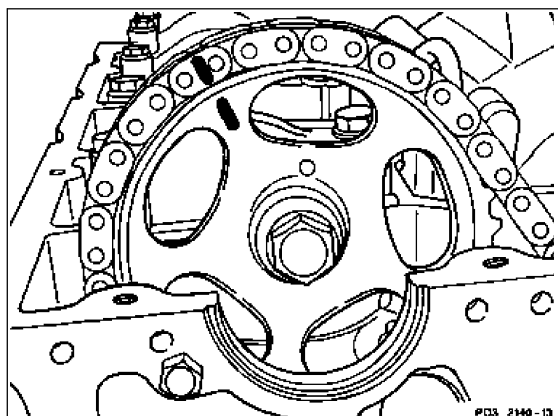

9 Pull off crankshaft sprocket with puller 102 589 05 33 00

10 Check condition of retaining wedge in crankshaft, renew, if required.

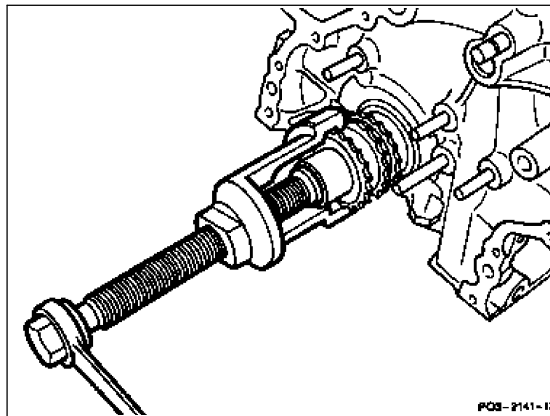

## Installation

11 Transfer color code from old crankshaft sprocket to new crankshaft sprocket.

12 Knock crankshaft sprocket onto crankshaft with installation punch 116 589 07 15 00. Pay attention to retaining wedge.

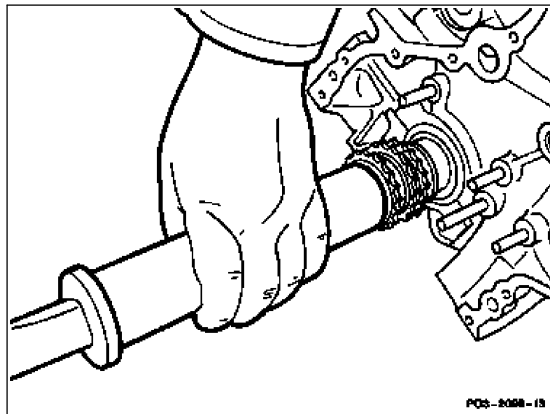

13 Install camshaft sprocket and timing chain paying attention to marking and tighten.

Tightening torque and rotation angle  
Hex. head bolt 65 Nm,  
12-point bolt 25 Nm, 90°.

14 Install chain tensioner and renew sealing ring (05-310).

15 Continue to turn crankshaft and check adjustment marking at TDC (arrows).

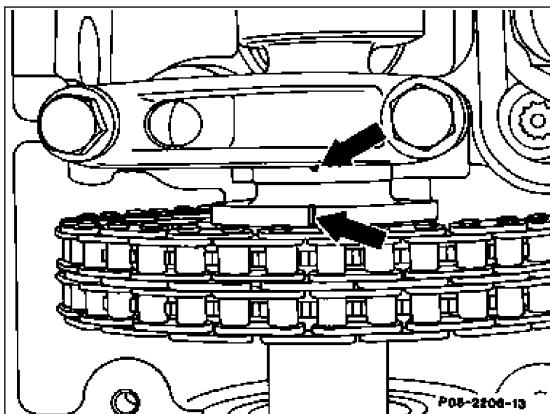

16 Install chain for oil pump drive together with oil pump chain sprocket and tighten.

### Note

Install oil pump sprocket so that arch points toward oil pump (arrows).

Tightening torque 25 Nm.

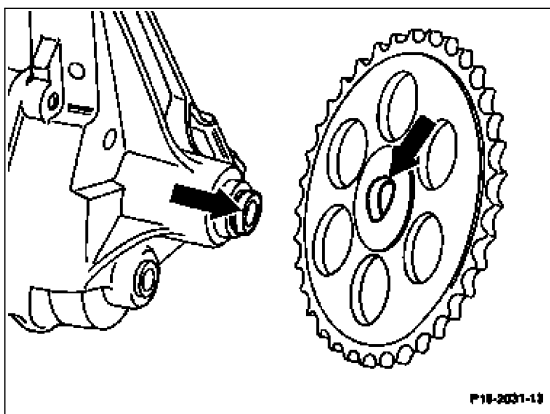

17 Attach clamping bracket (262) and torsion spring (261).

18 Run engine and check for leaks.

